

**ROBE**

**ROBIN<sup>®</sup> Spider**

**ROBIN<sup>®</sup> Spider**

Wireless DMX

CRMX™

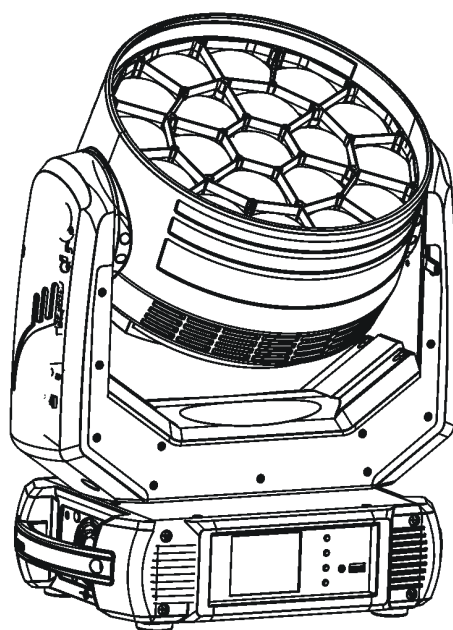

 **ROBIN<sup>®</sup>**  
Innovative Technology

QR code for user manual



**USER MANUAL**

ROBE<sup>®</sup> lighting s.r.o. • Czech Republic • [www.robe.cz](http://www.robe.cz)

Version 3.3

# Robin Spider

## Table of contents

<b>1. Safety instructions</b> .....	<b>3</b>
<b>2. Operating determination</b> .....	<b>4</b>
<b>3. Fixture exterior view</b> .....	<b>6</b>
<b>4. Installation</b> .....	<b>7</b>
4.1 Connection to the mains .....	7
4.2 Eggcrate installation .....	7
4.3 Diffuser installation .....	8
4.4 Rigging the fixture .....	9
4.5 DMX-512 connection .....	11
4.6 Ethernet connection .....	12
4.7 Wireless DMX operation .....	14
<b>5. Remotely controllable functions</b> .....	<b>15</b>
<b>6. Control menu map</b> .....	<b>17</b>
<b>7. Control menu</b> .....	<b>20</b>
7.1 Tab " Address" .....	21
7.2 Tab "Information" .....	22
7.3 Tab "Personality" .....	23
7.4 Tab "Manual Control" .....	25
7.5 Tab "Stand-alone" .....	25
7.6 Tab "Service" .....	26
<b>8. RDM</b> .....	<b>29</b>
<b>9. Error and information messages</b> .....	<b>31</b>
<b>10. Technical Specifications</b> .....	<b>32</b>
<b>11. Maintenance and cleaning</b> .....	<b>33</b>
11.1 Removing the optical module .....	35
11.2 Disposing of the product .....	37
<b>12. ChangeLog</b> .....	<b>37</b>
<b>13. Photometric diagrams</b> .....	<b>38</b>
<b>14. Appendix - DMX modes overview</b> .....	<b>40</b>

**CAUTION!**  
***Keep this device away from rain and moisture!***  
***Unplug mains lead before opening the housing!***

**FOR YOUR OWN SAFETY, PLEASE READ THIS USER MANUAL CAREFULLY  
BEFORE YOU INITIAL START - UP!**

## **1. Safety instructions**

Every person involved with installation and maintenance of this device have to:

- be qualified
- follow the instructions of this manual

**CAUTION!**  
***Be careful with your operations.***  
***With a high voltage you can suffer***  
***a dangerous electric shock when touching the wires!***

This device has left our premises in absolutely perfect condition. In order to maintain this condition and to ensure a safe operation, it is absolutely necessary for the user to follow the safety instructions and warning notes written in this manual.

### **Important**

The manufacturer will not accept liability for any resulting damages caused by the non-observance of this manual or any unauthorized modification to the device.

Please consider that damages caused by manual modifications to the device are not subject to warranty.

Handle the power cord and all connections with the mains with particular caution!

Make sure that the available voltage is not higher than stated on the rear panel.

**WARNING!** This unit does not contain an ON/OFF switch. Always disconnect power input cable to completely remove power from unit when not in use or before cleaning or servicing the unit.

Make sure that the power-cord is never crimped or damaged by sharp edges. Check the device and the power-cord from time to time.

Always disconnect from the mains, when the device is not in use or before cleaning it. Only handle the power-cord by the plug. Never pull out the plug by tugging the power cord.

This device falls under protection class I. Therefore it is essential to connect the yellow/green conductor to earth.

The electric connection, repairs and servicing must be carried out by a qualified employee.

Do not connect this device to a dimmer pack.

During the initial start-up some smoke or smell may arise. This is a normal process and does not necessarily mean that the device is defective.

Do not touch the device's housing bare hands during its operation (housing becomes hot)!  
For replacement use fuses of same type and rating only.

**LED light emission. Risk of eye injury. Do not look into the beam at short distance of the of the product. Do not view the light output with optical instruments or any device that may concentrate the beam.**  
**The light source contains blue LEDs.**

## 2. Operating determination

This device is a moving head for creating decorative effects and was designed for indoor use only.

This device is for professional use only. It is not for household use.

If the device has been exposed to drastic temperature fluctuation (e.g. after transportation), do not switch it on immediately. The arising condensation water might damage your device. Leave the device switched off until it has reached room temperature.

Do not shake the device. Avoid brute force when installing or operating the device.

Never lift the fixture by holding it at the projector head, as the mechanics may be damaged. Always hold the fixture at the transport handles.

When choosing the installation spot, please make sure that the device is not exposed to extreme heat, moisture or dust. There should not be any cables lying around. You endanger your own and the safety of others!

Make sure that the area below the installation place is blocked when rigging, derigging or servicing the fixture.

Always secure the fixture with an appropriate safety wire.

Only operate the fixture after having checked that the housing is firmly closed and all screws are tightly fastened.

The maximum ambient temperature 45°C must never be exceeded.

**To avoid damage of an internal optical system of the fixture, never let the sunlight (or other light source) lights directly to the lens array, even when the fixture is not working**

Operate the device only after having familiarized with its functions. Do not permit operation by persons not qualified for operating the device. Most damages are the result of unprofessional operation!

Please use the original packaging if the device is to be transported.

Please consider that unauthorized modifications on the device are forbidden due to safety reasons!

If this device will be operated in any way different to the one described in this manual, the product may suffer damages and the guarantee becomes void. Furthermore, any other operation may lead to dangers like short-circuit, burns, electric shock, burns etc.

**Potential foggy front lens array does not influence function of the fixture and does not subject to complaint.**

**Always push the zoom module into the head before inserting the fixture into the flight case.**

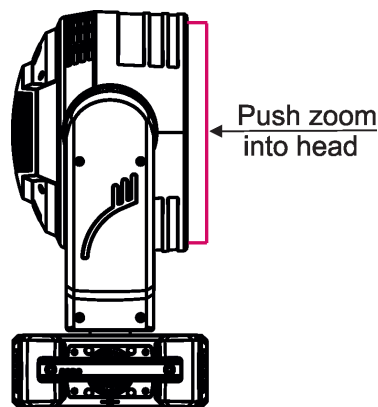

Immunity of the equipment is designed for electromagnetic environments E1, E2, E3 according to the standard EN55103-2 ed.2 Electromagnetic compatibility. Product family standard for audio, video, audiovisual and entertainment lighting control apparatus for professional use. Part 2: Immunity.

The installation company should check levels of possible interferences above the tested levels E1,E2,E3 given by this standard (e.g. transmitters in surrounding area) before installing the equipment.

Emission of the equipment complies with the standard EN55032 Electromagnetic compatibility of multimedia equipment – Emission Requirements according to class B.

### 3. Fixture exterior view

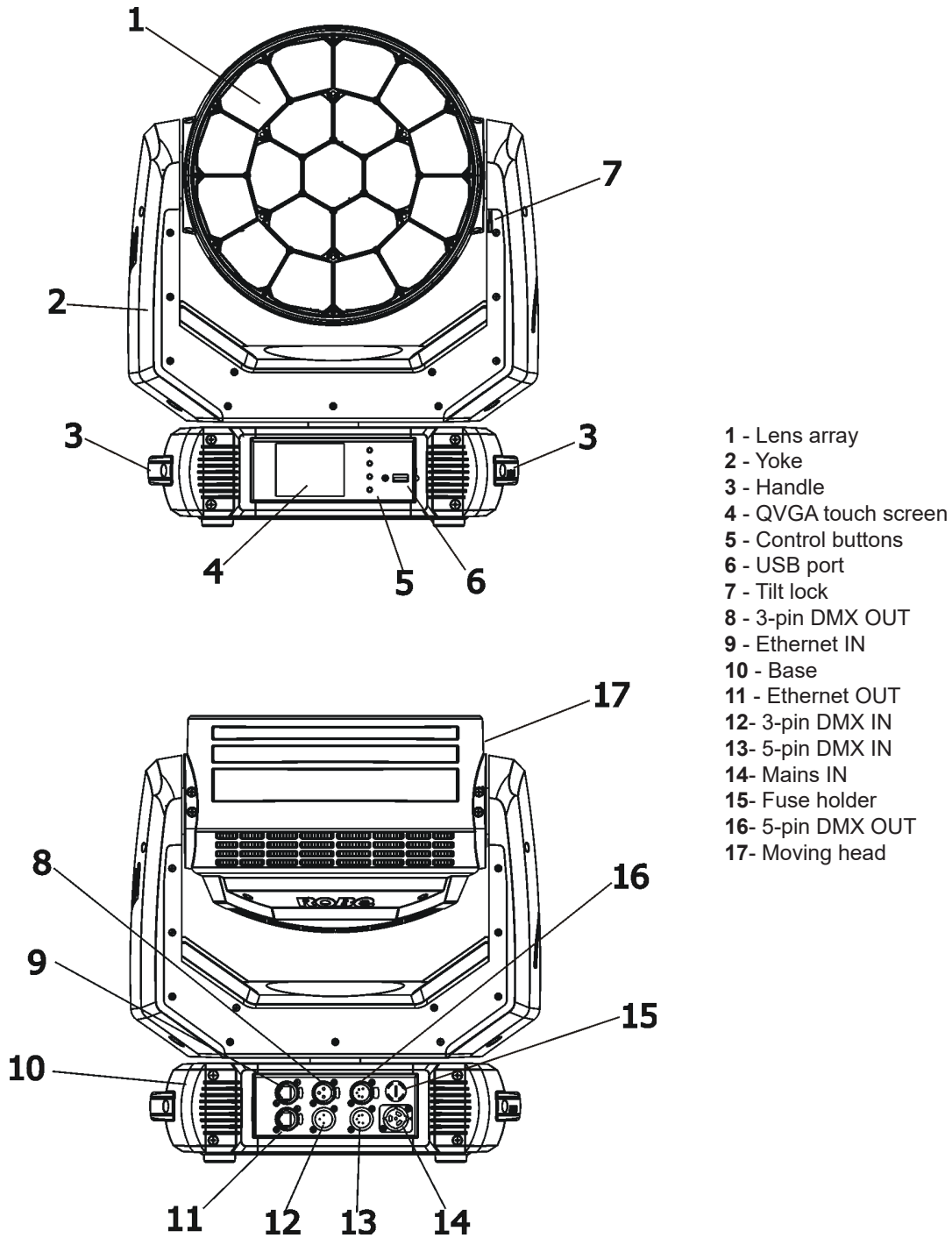

The head should be locked for transportation - the tilt lock latch (7) has to be in the locked position. To unlock the head, move this latch to unlock position before operating the fixture.

The ENTER/DISPLAY ON button also serves for switching the display on when the fixture is disconnected from the mains.

## 4. Installation



**Fixtures must be installed by a qualified electrician in accordance with all national and local electrical and construction codes and regulations.**

### 4.1 Connection to the mains

**For protection from electric shock, the fixture must be earthed!**

The Robin Spider is equipped with auto-switching power supply that automatically adjusts to any 50-60Hz AC power source from 100-240 Volts.

If you install a cord cap on the power cable to allow connection to power outlets, install a grounding-type (earthed) plug, following the plug manufacturer's instructions.

The cores in the power cable are coloured according to the following table.

Core (EU)	Core (US)	Connection	Plug Terminal Marking
Brown	Black	Live	L
Light blue	White	Neutral	N
Yellow/Green	Green	Earth	

This device falls under class one and must be earthed (grounded)!  
To apply power, first check that the head pan and tilt locks are released.  
Wiring and connection work must be carried out by qualified staff!

### 4.2 Eggcrate installation

**Disconnect the fixture from mains before eggcrate installation**

Screw the eggcrate (1) to the zoom module (3) by means of the three screws (2). It is possible to screw another eggcrate to the installed eggcrate.

Do not install the eggcrate on the zoom module with diffuser.

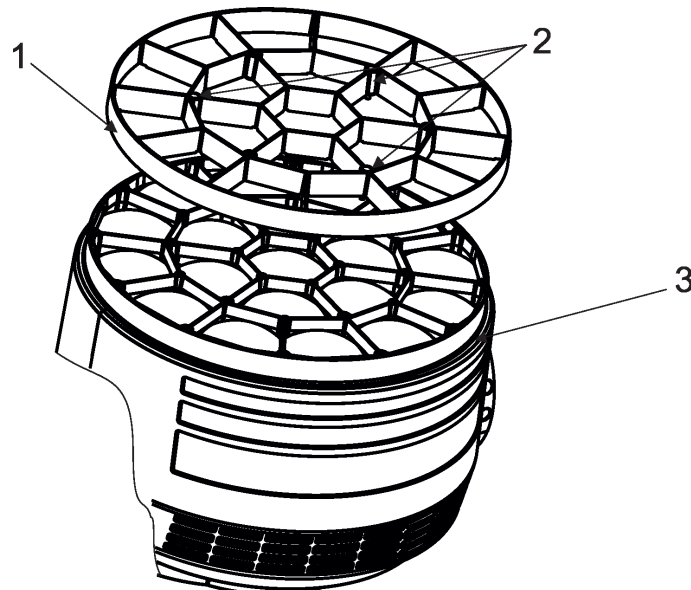

### 4.3 Diffuser installation

**Disconnect the fixture from mains before diffuser installation**

Screw the diffuser (1) to the zoom module (2) by means of the six screws M3x8 with washers (3). Glossy side towards lens arrays.

There is a marked shape (4) of the middle pixel on the plastic film. If you wish to use a pure flower effect (create by means of the middle pixel), remove the marked film from diffuser before its installation. Put the diffuser on the flat surface (be careful not to scratch it) and use a sharp knife to remove the marked plastic film (4).

Note: the diffuser can be installed on the eggcrate, in this case use only three screws M3x8 with washers.

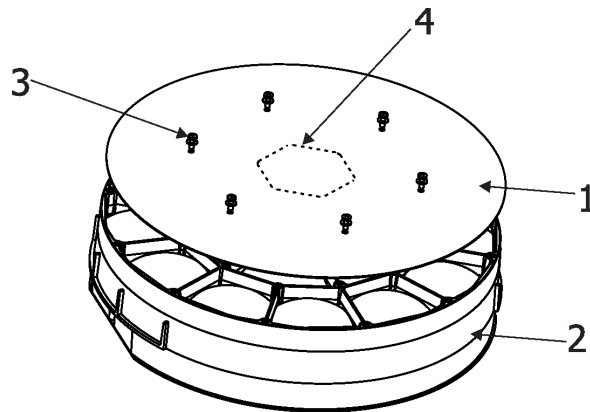



## 4.4 Rigging the fixture

A structure intended for installation of the fixture (s) must safely hold weight of the fixture(s) placed on it. The structure has to be certificated to the purpose.

The fixture (fixtures) must be installed in accordance with national and local electrical and construction codes and regulations.

***For overhead installation, the fixture must be always secured with a safety wire that can bear at least 10 times the weight of the fixture.***

When rigging, derigging or servicing the fixture staying in the area below the installation place, on bridges, under high working places and other endangered areas is forbidden.

The operator has to make sure that safety-relating and machine-technical installations are approved by an expert before taking into operation for the first time and after changes before taking into operation another time.

The operator has to make sure that safety-relating and machine-technical installations are approved by a skilled person once a year.

Allow the fixture to cool for ten minutes before handling.

The fixture should be installed outside areas where persons may walk by or be seated.

IMPORTANT! OVERHEAD RIGGING REQUIRES EXTENSIVE EXPERIENCE, including calculating working load limits, installation material being used, and periodic safety inspection of all installation material and the projector. If you lack these qualifications, do not attempt the installation yourself, but use a help of professional companies.

CAUTION: Fixtures may cause severe injuries when crashing down! If you have doubts concerning the safety of a possible installation, do not install the fixture!

The fixture has to be installed out of the reach of public.

The fixture must never be fixed swinging freely in the room.

**Danger of fire !**  
**When installing the device, make sure there is no highly inflammable material (decoration articles, etc.) in a distance of min. 0.5 m.**

**CAUTION!**  
**Use 2 appropriate clamps to rig the fixture on the truss.**  
**Follow the instructions mentioned at the bottom of the base.**  
**Make sure that the device is fixed properly! Ensure that the structure (truss) to which you are attaching the fixtures is secure.**

The fixture can be placed directly on the stage floor or rigged in any orientation on a truss without altering its operation characteristics .

For securing the fixture to the truss, install a safety wire which can hold at least 10 times the weight of the fixture. Use only the safety wire with a snap hook with screw lock gate.

### Truss installation

1. Bolt the clamp (3) to the omega holder (5) with M12 bolt and lock nut through the hole in the holder.
2. Fasten the omega holders to the bottom of the base by inserting both quick-lock fasteners (2) into the holes of the base and tighten fully clockwise.
3. Clamp the fixture on a truss (6) and tighten the rigging clamps.
4. Pull the safety wire (4) through the attachment point (1) and through the handle (7) and around the truss (6) and lock the snap hook with screw lock gate.

Use only a safety wire with a snap hook with screw lock gate.

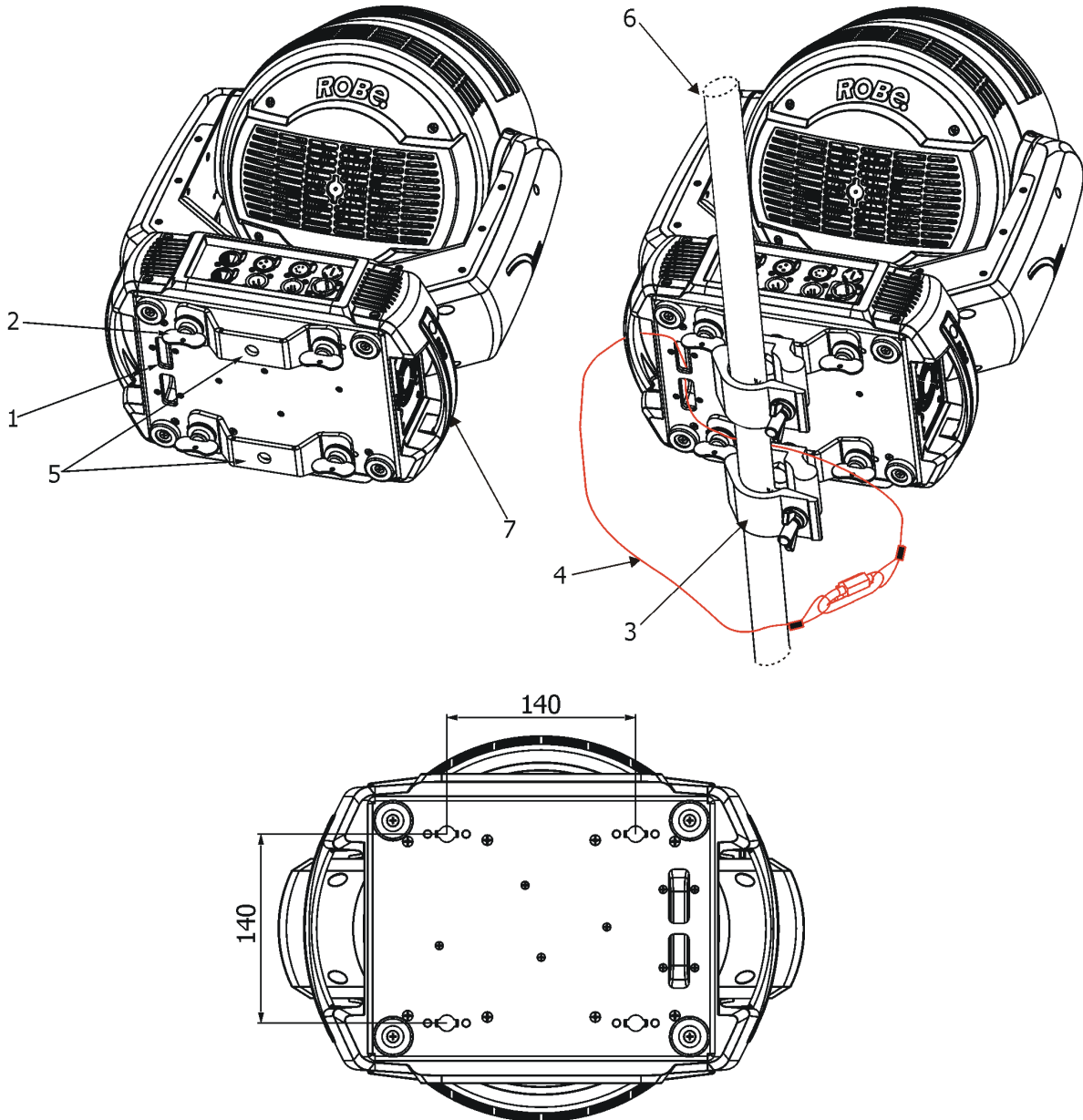

**When installing fixtures side-by-side,  
avoid illuminating one fixture with another!**

**DANGER TO LIFE!**  
**Before taking into operation for the first time, the installation has to be approved by  
an expert!**

**In order to protect the internal parts of the head from the sun, the function PARKING POSITION must be switched ON before switching the fixture off.**

The PARKING POSITION function is located on the Power/Special functions channel (120-129 DMX). If the function is on, the fixture will automatically detect via G-sensor whether the fixture is on the floor or hangs on the truss or is mounted sideways on the truss and moves the pan and tilt to the position (including movement of zoom to the front part of the head) in which the head will always face down. Owing this position of the fixture head, there is not chance to burn internal parts of the head by the sun light.

### 4.5 DMX-512 connection

The fixture is equipped with both 3-pin and 5-pin XLR sockets for DMX input and output. The sockets are wired in parallel.

Only use a shielded twisted-pair cable designed for RS-485 and 3-pin or 5-pin XLR-plugs and connectors in order to connect the controller with the fixture or one fixture with another.

#### DMX - output

XLR mounting-sockets (rear view):

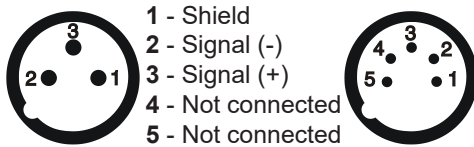

#### DMX-input

XLR mounting-plugs (rear view):

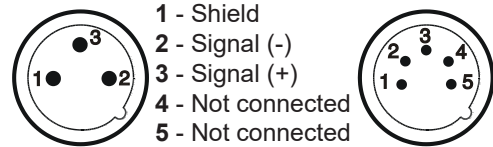

#### Building a serial DMX-chain:

Connect the DMX-output of the first fixture in the DMX-chain with the DMX-input of the next fixture. Always connect one output with the input of the next fixture until all fixtures are connected. Up to 32 fixtures can be connected.

**Caution:** At the last fixture, the DMX-cable has to be terminated with a terminator. Solder a 120 Ω resistor between Signal (-) and Signal (+) into a 3-pin (5-pin) XLR-plug and plug it in the DMX output of the last fixture.

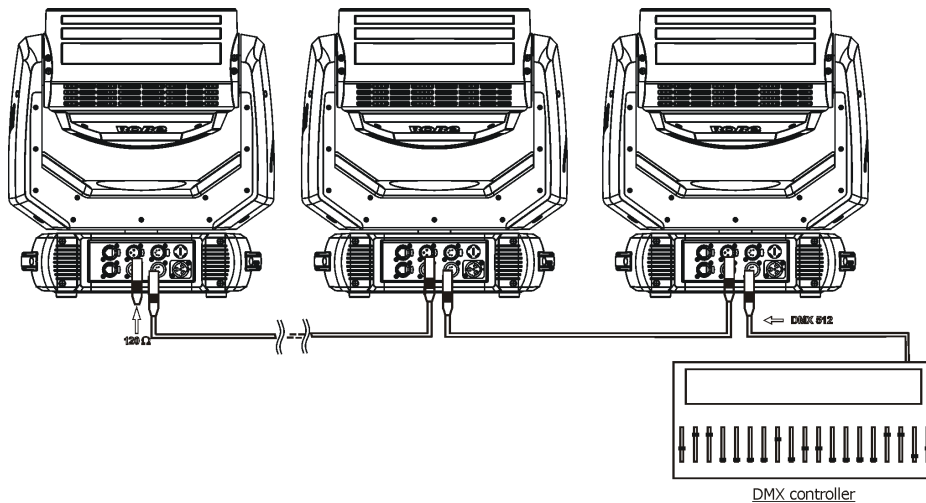

## 4.6 Ethernet connection

The fixtures on a data link are connected to the Ethernet with appropriate communication protocol (e.g. Art-Net). The control software running on your PC (or light console) has to support Art-Net protocol. Art-Net communication protocol is a 10 Base T Ethernet protocol based on the TCP/IP. Its purpose is to allow transfer of large amounts of DMX 512 data over a wide area using standard network technology.

**IP address** is the Internet protocol address. The IP uniquely identifies any node (fixture) on a network. **The Universe** is a single DMX 512 frame of 512 channels.

The Robin Spider is equipped with 8-pin RJ-45 sockets for Ethernet connection. Use a network cable category 5 (with four "twisted" wire pairs) and standard RJ-45 plugs in order to connect the fixture to the network.

**RJ-45 socket (front view):**



- |                  |                  |
|------------------|------------------|
| 1- TD+           | 5- Not connected |
| 2- TD-           | 6- RX-           |
| 3- RX+           | 7- Not connected |
| 4- Not connected | 8- Not connected |

**RJ-45 plug (front view):**

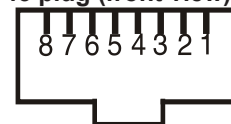

Patch cables that connect fixtures to the hubs or LAN sockets are wired 1:1, that is, pins with the same numbers are connected together:



If only the fixture and the computer are to be interconnected, no hubs or other active components are needed. A cross-cable has to be used:



If the fixture is connected with active Ethernet socket (e.g. switch) the network icon  will appear at the bottom right corner of the screen:

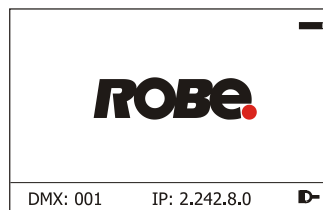

### Ethernet operation

Connect the Ethernet inputs of all fixtures with the Ethernet network. Option "Artnet (gMal or gMA2)" has to be selected from "Ethernet Mode" menu on the fixture. Set IP address (002.xxx.xxx.xxx / 010.xxx.xxx.xxx) and the Universe.

Example:

(DMX address=217)  
IP address=002.168.002.004  
Universe=1

(DMX address=28)  
IP address=002.168.002.003  
Universe=1

(DMX address=1)  
IP address=002.168.002.002  
Universe=1

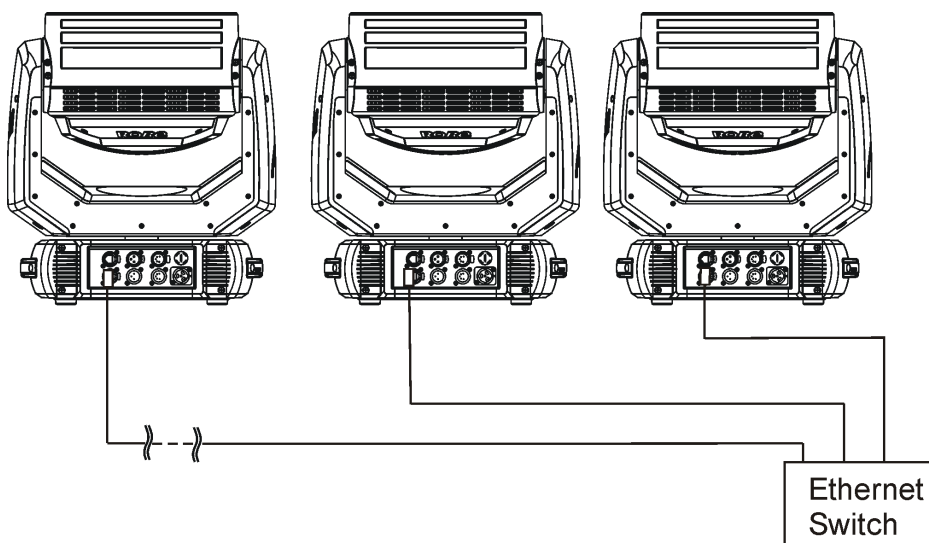

An advised PC setting: IP address: 002.xxx.xxx.xxx / 010.xxx.xxx.xxx (Different from fixture IP addresses)  
NET mask: 255.0.0.0

If you use fixture's Ethernet IN/Ethernet OUT ports for Ethernet IN-OUT connection, max. 8 fixtures can be connected in the IN-OUT line.

### Ethernet / DMX operation

Options "Ethernet To DMX" has to be selected from the "Ethernet Settings" menu on the first fixture (connected to the Ethernet) in the fixture chain, next fixtures have standard DMX setting.

Connect the Ethernet-input of the first fixture in the data chain with the network. Connect the DMX output of this fixture with the input of the next fixture until all fixtures are connected to the DMX chain.

**Caution:** At the last fixture, the DMX chain has to be terminated with a terminator. Solder a 120 Ω resistor between Signal (-) and Signal (+) into a XLR-plug and connect it in the DMX-output of the last fixture.

Example:

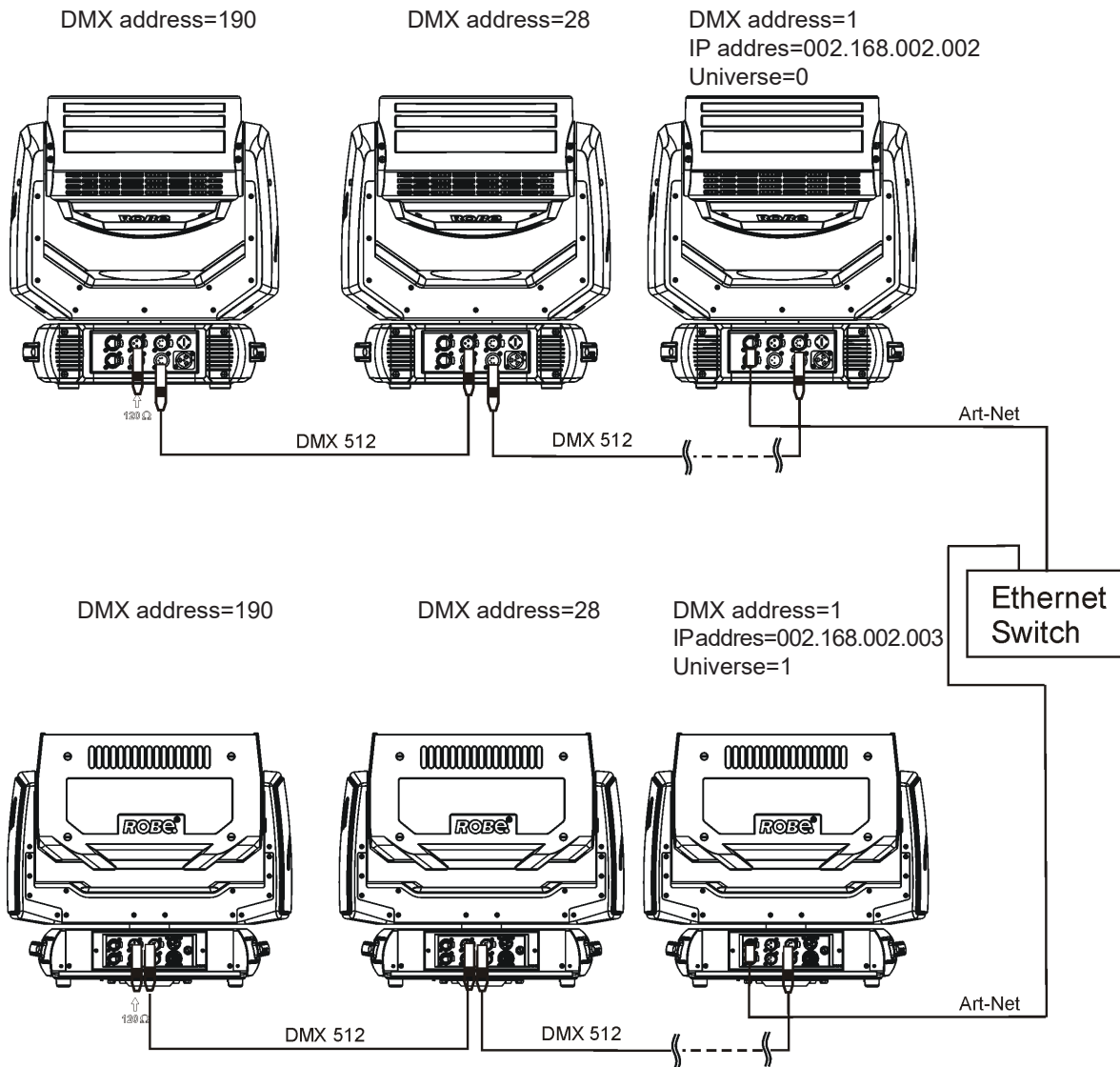

## 4.7 Wireless DMX operation

The wireless version of the Robin Spider is equipped with the Lumen Radio CRMX module and antenna for receiving DMX signal. CRMX module operates on the 2.4 GHz band.

The item " Wireless " from the menu "DMX Input" allows you to activate receiving of wireless DMX (Personality--> DMX Input -->Wireless.). First two options from the "DMX Input" menu are stated in DMX chart as well (channel Power/Special functions , range of 10-19 DMX). If DMX input option is changed by DMX command, the change is permanently written into fixture's memory.

**DMX range of 10-19 switching fixture to the wired/wireless operation is active only during first 10 seconds after switching the fixture on.**

After switching the fixture on, the fixture checks both modes of receiving DMX in the following order:

1. For the first five seconds, the fixture receives DMX signal from the wired input. If the Power/Special functions channel is set at some DMX input option, the fixture will receive DMX value according to this option. If DMX input option is set to the wired input , this option is saved and checking procedure is finished. If DMX input option is not set, the fixture continues next 5 seconds in scanning wireless DMX signal-see point 2.

2. For the next 5 seconds the fixture receives wireless DMX signal and again detects if the Power/Special functions channel is set at some DMX input option, if not, the fixture will take option which is set in the fixture menu "DMX Input".

### To link the fixture with DMX transmitter.

The fixture can be only linked with the transmitter by running the link procedure at DMX transmitter . After linking , the level of DMX signal ( 0-100 %) is displayed in the menu item "Wireless State" (Information -->Wireless State).

### To unlink the fixture from DMX transmitter.

The fixture can be unlinked from receiver via the menu item " Unlink Wireless Adapter" (Information--> Wireless State --> Unlink Wireless Adapter).

**Note:** If the option "Wireless In/XLR Out" is selected (Personality--> DMX Input -->Wireless In/XLR Out), the fixture receives wireless DMX and sends the signal to its wired DMX output. The fixture behaves as " Wireless/ Wired" adapter.

Example:

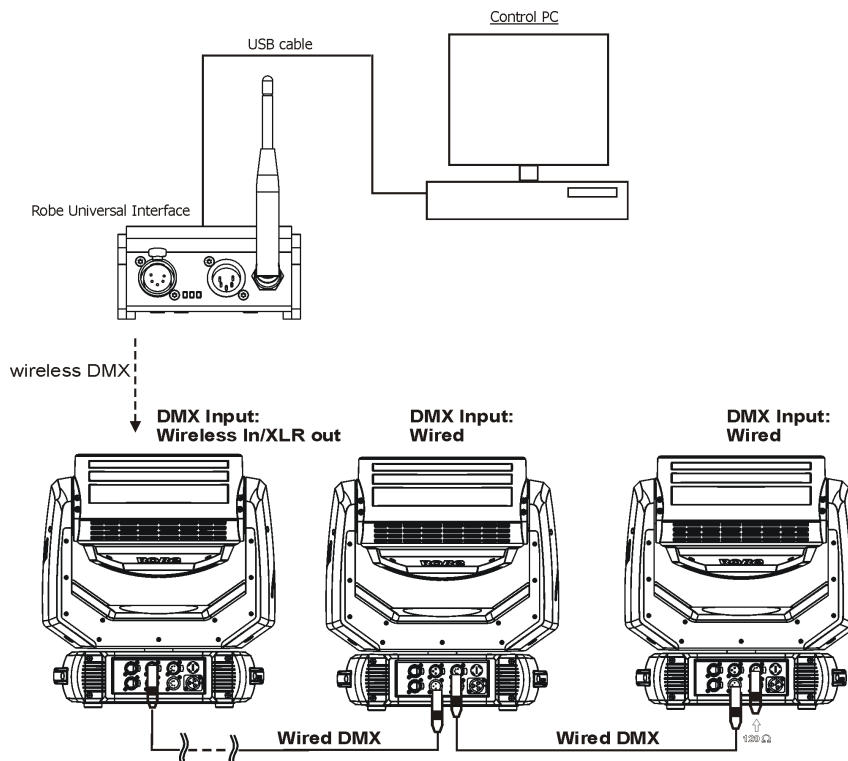

## 5. Remotely controllable functions

### Virtual colour wheel

This wheel contains 66 preset colours, rainbow effect in both directions is available.

### Colour temperature correction (CTC)

This channel allows to set calibrated white colour from range of 8000K-2700K.

### RGBW or CMY colour mixing system

The RGBW colour mixing system is based on red, green, blue and white high power LEDs. Option for switching the fixture to the CMY colour mixing system is available.

### Colour Mix control

The Colour Mix control channel defines relation between global colours (RGBW, CTO, Virtual colour wheel) and individual RGB pixels or Kling-Net.

Global = Global Colours (RGBW, CTO, Virtual Color Wheel)

Pixel = Pixel Colors (RGB individual pixels or Kling-Net)

DMX value	Function
0-9	Global colours (Global has priority)
10-19	Maximum mode (highest values have priority)
20-29	Minimum mode (lowest values have priority)
30-39	Multiply mode (multiply Global and Pixel)
40-49	Addition mode (Global + Pixel) - default
50-59	Subtraction mode (Global – Pixel)
60-69	Inverted Subtraction mode (Pixel – Global)
70-79	Coloured background
80-127	Reserved
128	Global colours (Global has priority)
129-254	Crossfade (crossfade between Global and Pixel)
255	Pixel colours (Pixel has priority)

E.g. If you wish to control RGBW channels, set the Colour Mix Control channel to 0 DMX, if you need to use pixel effects, set the Colour Mix Control channel to 255 DMX.

### Flower Effect

The flower effect rotating in both directions allows to create many dynamic effects.

### Zoom

Motorized zoom offers beam range of 4° to 50°.

### Pixel control and pixel effects

19 RGB pixels allow you to create many effects or use 90 pre-defined pixel effects

Pixel order:

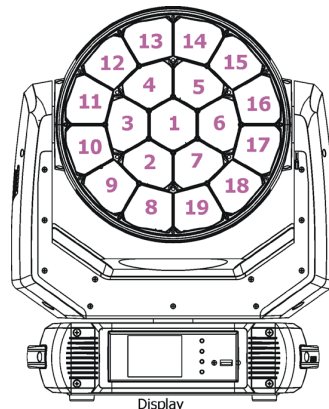

Pan=128

Tilt=235

### Dimmer/Shutter unit

Smooth 0 - 100 % dimming is provided by the electronic control unit. This unit is also used for strobe effects with variable speed.

## Pan/Tilt

Precise pan/tilt movement due to built-in electronic motion stabilizer. The electronic motion stabilizer ensures precise position of the fixture's head during its movement and reduces its swinging when the truss shakes. Pan movement range: 540°, tilt movement range: 220°.

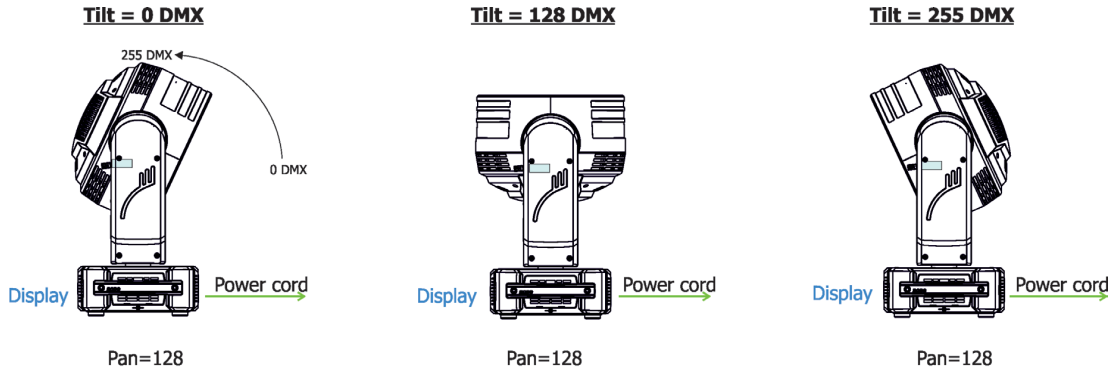

**Tilt movement range: 220° Pan movement range: 540°**

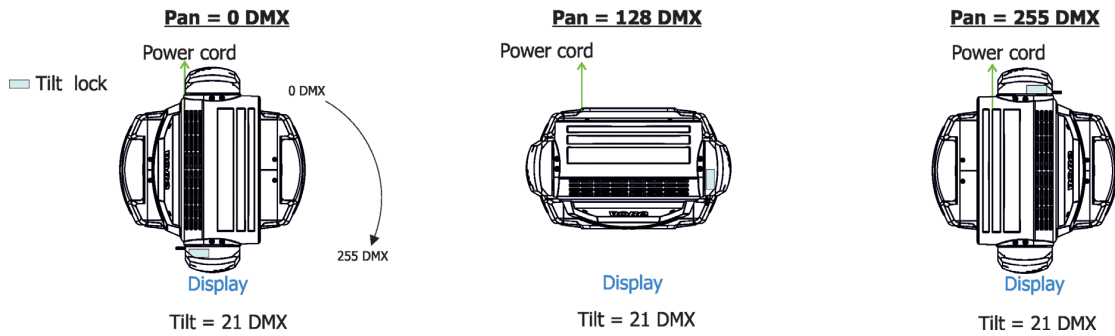







## 6. Control menu map

Default settings=**Bold print**

Tab	Level 1	Level 2	Level 3	Level 4	Level 5	Level 6
Addressing	Settings	DMX Address	001-512			
		DMX Preset	<b>Mode 1</b> , Mode 2, Mode 3, Mode 4			
		Ethernet Settings	Ethernet Mode	Disable		
				ArtNet		
				gMA1		
				gMA2		
				sACN		
			Ethernet To DMX	<b>Off</b> , On		
			IP Address/Net Mask	Default IP Address		
				Custom IP Address		
				Net Mask		
			ArtNet Universe	0-255		
			MANet settings	MANet/II Universe	01-256	
				MANet Session ID	01-32	
			sACN Settings	sACN Universe	00001-32000	
				sACN Priority	0-255	
			Klingnet Settings	<b>Disable</b>		
				Enable		
Information	Fixture Times	Power On Time	Total Hours			
			Resetable Hours			
		Air Filters	Elapsed Time			
			Alert Period	10-300		
	Fixture Temperatures	LEDs Temperature	Current			
			Maximum NonRes.			
			Maximum Res.			
		Base Temperature	Current			
			Maximum NonRes.			
			Maximum Res.			
	DMX Values	Pan				
		:				
		Blue Pixel 19				
	Wireless State	Signal Quality				
		Unlink Wireless Adapter				
	Power Channel State					
	Software Versions	Display System				
		Module M				
		Module DR				
		Module PX				
	Product IDs	Mac Address				
		RDM UID				
		RDM Label				
	View Logs	Fixture Errors				
		Fixture States	Power On			
			Power Off			
		Fixture Position				
		Fixture Temperatures	LEDs Temperatures			
			Base Temperatures			

Tab	Level 1	Level 2	Level 3	Level 4	Level 5	Level 6
Personality						
	DMX Presets	Mode 1				
		:				
		<b>Mode 6</b>				
		:				
		Mode 10				
		View Selected Preset				
	DMX Input	<b>Wired Input</b>				
		Wireless Input				
		Wireless In/XLR Out				
	Pan/Tilt Settings	Pan Reverse	<b>Off, On</b>			
		Tilt Reverse	<b>Off, On</b>			
		Pan/Tilt Feedback	<b>Off, On</b>			
		Pan/Tilt mode	Time			
			<b>Speed</b>			
	Pan/Tilt EMS	<b>On, Off</b>				
	Pixel Control	Pixel Index	<b>0-11</b>			
		Pixel Mirror	<b>On, Off</b>			
		Reset to default				
	Microphone Sensitivity	<b>1-10-20</b>				
	Blackout Settings	Blackout During M.C.	<b>Off, On</b>			
		Blackout while:	Pan/Tilt moving	<b>Off, On</b>		
	Colour Mixing Mode	<b>RGBW</b>				
		CMY				
	White Point 8000K	<b>Off, On</b>				
	Tungsten Eff. Sim.	<b>Off</b>				
		750W				
		1000W				
		1200W				
		2000W				
		2500W				
	Dimmer Curve	Linear				
	<b>Square Law</b>					
LEDs Output Frequency	<b>Standard High</b>					
LEDs Frequency Adjust	<b>-6....0....+6</b>					
Init Effect Positions	Pan	0-255				
	:					
	Dimmer Fine	0-255				
Screen Settings	Display Intensity	<b>1-10</b>				
	Screen Saver Delay	<b>Off-10min.</b>				
	Touchscreen Lock	<b>Off-10min.</b>				
	Recalibrate Touchscreen					
	Display Orientation	Normal				
		Inverted				
		<b>Auto</b>				
Temperature Unit	<b>°C, °F</b>					
Fan Mode	<b>Auto</b>					
	High					
	Silent					
Date & Time Settings						
Default Settings						
Manual Control	Reset Functions	Total System reset				
		Pan/Tilt reset				
		Zoom Reset				

Tab	Level 1	Level 2	Level 3	Level 4	Level 5	Level 6
		Flower E. Reset				
	Manual Effect Control	Pan	0-255			
		:				
		Blue Pixel 19	0-255			
Stand -Alone	Test Sequences	Dynamic Mode				
		Static Mode	Pan	0-255		
			Tilt	0-255		
			Zoom	0-255		
	MusicTrigger	Off, On				
	Preset Playback	None				
		Test				
		Prog. 1				
		Prog. 2				
		Prog. 3				
	Play Program	Play Program 1				
		Play Program 2				
		Play Program 3				
	Edit Program	Edit Program 1	Start Step	1-100		
			End Step	1-100		
			Edit Program Steps	Step 1	Pan	0-255
				:	:	
				:	Dimmer Fine	0-255
				:	Step Time	0-25,5 sec.
				Step 100	Pan	0-255
					:	
					Dimmer Fine	0-255
					Step Time	0-25,5 sec.
Service	Adjust DMX Values	Pan	0-255			
		:				
		Blue Pixel 19	0-255			
	Calibrations	Calibrate Effects	Pan	0-255		
			Tilt:	0-255		
			FE rotation	0-255		
		Calibrate colours	Red	0-255		
			Green	0-255		
			Blue	0-255		
			White	0-255		
			Red Intensity	0-255		
			Green Intensity	0-255		
			Blue Intensity	0-255		
			White intensity	0-255		
		Pixel Correction	Red 1	0-255		
			Green 1	0-255		
			Blue 1	0-255		
			White 1	0-255		
			:			
			Red 19	0-255		
			Green 19	0-255		
			Blue 19	0-255		
			White 19	0-255		
		Calibrate Pan/Tilt EMS				
		Load Default Calibrations				
	Update Software					

## 7. Control menu

The Robin Spider Light is equipped with the QVGA Robe touch screen with battery backup which allows to set the fixture's behaviour according to your needs, obtain information on its operation, test its various parts and lastly program it, if it has to be used in a stand-alone mode.

The fixture's menu can be controlled either by the control buttons or directly by touching the icon.

### Control buttons on the front panel:

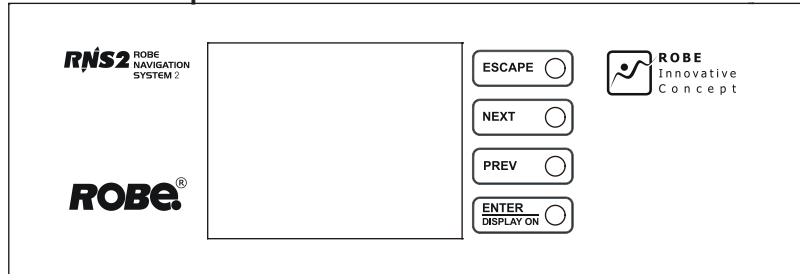

[ESCAPE] button used to leave the menu without saving changes.

[NEXT] , [PREV] buttons for moving between menu items and symbols, adjusting values.

[ENTER/Display On] button used to enter the selected menu (menu item) and to confirm adjusted value.

If the fixture is disconnected from mains, the button switches the touch screen on.

### Icons used in the touch screen menu:



- [back arrow] used to move back to the previous screen (menu).



- [up arrow] used to move up on the previous page.



- [down arrow] used to move down on the next page.



- [confirm] used to save adjusted values, to leave menu or to perform desired action.



- [cancel] used to leave menu item without saving changes.



- [confirm+copy] used to save adjusted values and copy them to the next prog. step.



- [warning icon] used to indicate some error which has occurred in the fixture.



- [Ethernet] used to indicate Ethernet connected.



- [display turn] used to turn the display by 180°.



- [slider control] used to recall slider system for setting desired value.



- [keyboard control] used to recall keyboard system for setting desired value.



- [air filters cleaning] used to signal that cleaning period of the air filters elapsed.

The menu page displays icons for each function that you can perform from the touch screen.

After switching the fixture on, the touch screen shows the screen with the ROBE logo:

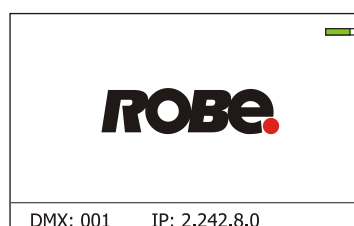

Note: The green icon at the top right corner of the screen indicates the level of the display battery charging. If the whole icon is green, the battery is fully charged while the red icon indicates exhausted battery. The battery charges during fixture operation, its charging lasts cca 6 hours.

We recommend that the fixture should be in operation at least 7 hours per week to keep the battery fully charged. If you switch the fixture on and this screen will not appear till 1 minute, switch the fixture off and on again. If the screen lights, the battery is exhausted. In case the screen still does not light, the battery is faulty.

This is also indicated by an error message "Faulty battery" and if such an error message appears the battery should be replaced immediately. The lifetime of the battery is highly dependent on ambient temperature (and consequently on base temperature). If the maximum ambient temperatures (as recorded and displayed in menu: Information -> Fixture Temperatures -> Ambient Temperature -> Maximum NonRes.) are kept within the specified limits, the battery should last for at least two years. Should the ambient temperatures exceed the specified maximum temperature, the lifetime of the batteries could be considerably shortened even up to just one year or less and also result in physical damage (battery leakage) or unreliable fixture functions.

Damage caused by batteries failed due to exceeded maximum ambient temperature cannot be claimed under warranty terms.

Touch any part of the screen or press the [ENTER/Display On] button to display the initial screen with the current stored DMX address:

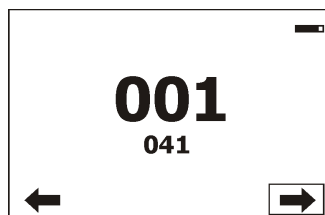

Touch the green arrow at the bottom right corner of the screen or press the [ENTER/Display On] button to enter the "Address" menu.

Each item (such as a Tab, menu item, text box, icon) may be selected from a screen by simply touching the item in the list or by pressing the [NEXT] or [PREV] buttons to scroll through items. With each press, the next item is highlighted. Press [ENTER/Display On] to select the highlighted item.

**Before first fixture operation, set current date and time in the menu "Date & Time Settings" (menu path: Personality--> Date & Time Settings).**

## 7.1 Tab "Address"



**DMX Address** - Select the menu to set the DMX start address.

**DMX Preset** - Use the menu to select desired channel mode.

**View Selected Preset** - Use the menu to display channels included in the selected mode.

**Ethernet Settings** - The menu allows all needed settings for the Ethernet operation

### **Ethernet Mode**

**Disable** - The option disables Ethernet operation.

**Artnet** - Fixture receives Artnet protocol

**gMA1** - Fixture receives MANet 1 protocol

**gMA2** - Fixture receives MANet 2 protocol

**sACN** - Fixture receives sACN protocol

**Ethernet To DMX** - Fixture receives protocol from the Ethernet input and sends DMX data to its DMX output (fixture works as an "Ethernet/DMX converter", next fixture can be connected to its DMX output and you can build a standard DMX chain by connecting another fixtures. Only one fixture has to be connected to the Ethernet.

**IP Address/Net Mask** - Select this menu to set IP address. IP address is the Internet protocol address. The IP uniquely identifies any node (fixture) on a network.

There cannot be 2 fixtures with the same IP address on the network!

**Default IP Address** - Preset IP address, you can set up only first byte of IP address (2 or 10) e.g. **002.019.052.086**.

**Custom IP Address** - The option enables to set up all bytes of IP address.

**Net Mask** - The option enables to set up all bytes of Net Mask.

**ArtNet Universe** - Use this item to set a Universe (0-255). The Universe is a single DMX 512 frame of 512 channels.

**MANet Settings** - Use this menu to set parameters for MANet operation.

**MANet Universe I/II** - The value of this item can be set in range 1-256.

**MANet Session ID** - The value of this item can be set in range 1-32.

**sACN Settings** - Use this menu to set parameters for sACN operation.

**sACN Universe** - The value of this item can be set in range 1-32000.

**sACN Priority** - The value of this item can be set in range 0-255.

**Klingnet Settings** - Use this menu to enable or disable Klingnet protocol.

## 7.2 Tab "Information"



**Fixture Times** - The menu provides readouts of fixture operation hours and air filters using hours.

**Power On Time Hours** - Select this menu to read the number of fixture operation hours.

**Total Hours** - The item shows the total number of the operation hours since the Robin Spider has been fabricated.

**Resetable Hours** - The item shows the number of the operation hours that the Robin Spider has been powered on since the counter was last reset.

In order to reset this counter to 0, touch the text box next to the item "Resetable Hours:"

**Air Filters** - Regular cleaning of the air filters is very important for the fixture's life and performance.

Build-up of dust, dirt and fog fluid residues reduces the fixture's light output and cooling ability.

The two items of this menu help you to keep cleaning period of the air filters.

**Alert period** - Cleaning schedule for the fixture depends on the operating environment.

It is therefore impossible to specify accurate cleaning interval. This item allows you to change the cleaning interval of the air filters. This "alert" value is 300 hours and it is set as default. Inspect the fixture within its 300 hours of operation to see whether cleaning is necessary. If cleaning is required, clean all air filters and change the value in this menu on acceptable level. Min. level of alert period is 10 hours, max. is 300 hours.

**Elapsed Time** - The item allows you to read the time which remains to cleaning air filters.

The time period is set in the menu mentioned above.

Expired time period is signalled by a negative mark (-) at the time value and a warning icon on the display.

Clean the filters and reset this menu item (by touching the text box next to the item "Elapsed Time").

**Fixture Temperatures** - The menu is used to view temperatures of the fixture's inside.

**LEDs temperatures** - The menu shows temperature on the LEDs PCB .

**Cur.** - A current temperature of the LEDs PCB.

**Max.** - A maximum temperature of the LEDs PCB since the fixture has been fabricated.

**Max. Res.** - A maximum temperature of the LEDs PCB since the counter was last reset.

In order to reset some counter to 0, touch desired text box under item "Max.Res."

**Base Temperature** - The menu shows temperature in the fixture base (on the display PCB).

**Current** - A current temperature in the fixture base.

**Maximum NonRes.** - A maximum temperature in the fixture base since the fixture has been fabricated.

**Maximum Res.** - A maximum temperature in the fixture base since the counter was last reset.  
In order to reset this counter to 0, touch the text box next to the item "Maximum Res."

**DMX Values** - The menu is used to read DMX values of each channel received by the fixture.

**Wireless State** - The menu serves for reading of the wireless operation status.

**Unlink Wireless Adapter** - The item serves for unlinking the fixture from DMX transmitter.

**Power Channel State** - The menu item shows state of the Power/Special functions switches.

**Software Version** - Select this item to read the software version of the fixture modules:

**Display System** - A display processor on the display board in the fixture base

**Module M** - A pan/Tilt processors

**Module DR** - A LEDs driver

**Module PX** - Pixels + zooms control

**Product IDs** - The menu is used to read the MAC Address ,RDM UID and RDM Label.

**View Logs** - Use this menu to read fixture's data which have been recorded during fixture operation. This collected data allows easier troubleshooting.

**Fixture Errors** - Use this menu to read fixture errors which have occurred during fixture operation.

**Fixture States** - Recorded following actions: Fixture On, Fixture Off.

**Fixture Position** - Recorded installation positions of the fixture:

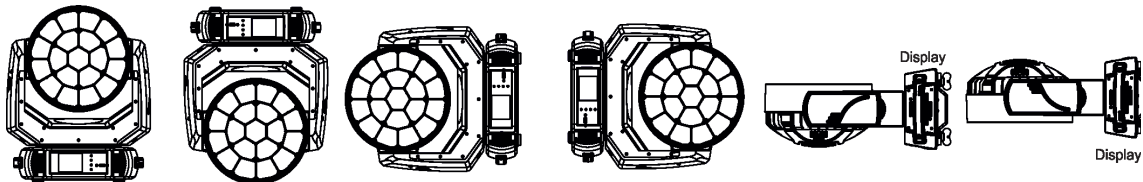

Disp-FN

Disp-FI

Disp-SB

Disp-ST

Disp-T

Disp-B

**Fixture Temperatures** - Recorded temperatures which have exceeded defined levels.

Note: The log buffer can contain 8000 records max. If the buffer is full, old data will be overwritten.

## 7.3 Tab "Personality"



**DMX Preset** - Use the menu to select desired channel mode.

**View Selected Preset** - Use the menu to display channels included in the selected mode.

**DMX Input** - Use the menu to select mode of DMX signal receiving.

**Wired** - DMX signal is received by means of the standard DMX cable.

**Wireless** - DMX signal is received by means of the inbuilt wireless module.

**Wireless In/XLR Out** - the fixture receives wireless DMX and sends the signal to its wired DMX output.

The fixture behaves as " Wireless/Wired" adapter.

The options "Wired" and "Wireless" are also stated in DMX chart (channel Power/Special functions).

Note. If the wireless module is not installed in the fixture, the following message will appear:

DMX Input Set to Wired

Wireless Module Missing

If the fixture is not connected to mains, the message "Not Available In Offline Mode" will appear after entering the menu DMX Input. To enter this menu, the fixture has to be connected to mains.

**Pan/Tilt Settings** - Use the menu set behaviour of both pan and tilt movements.

**Pan Reverse** - The item allows to invert pan movement.

**Tilt Reverse** - The item allows to invert tilt movement.

**Pan/Tilt Feedback** - The item allows to return the mowing head to the required pan/tilt position after changing the position by an external force if this option is set on.

Note. Be careful, the Pan/Tilt Feedback should be permanent On, the option Off is not suitable for standard operation and the head of the fixture can be damaged!

**Pan/Tilt mode** - Use this menu to set the mode of the pan/tilt movement

**Time mode** – The pan and tilt will move with different speeds and they will come at the same time to the end point of their tracks (pan and tilt use their optimal speeds).

Time of the pan/tilt movement (25.5 sec. max.) is set by the channel "Pan/Tilt speed, Pan/Tilt time".

**Speed Mode** - Both Pan and tilt will move with the same speed as adjusted at the channel "Pan/Tilt speed, Pan/Tilt time".

**Pan/Tilt EMS** - Built-in electronic motion stabilizer ensures precise position of the fixture's head during its movement and also reducing its swinging when the truss shakes.

**Pixel Control** - Use the menu to index or mirror pixels.

**Pixel Index** - The item allows you to choose 12 positions of turned pixels.

**Pixel Mirror** - The item allows mirroring of pixels along a vertical axis.

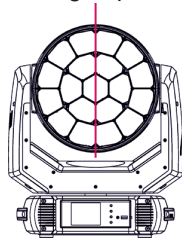

Both functions you can also find on the channel Power/Special functions (210-225 DMX).

**Important:** If you use DMX commands to set values for both Pixel Index and Pixel Mirror functions, set values will be lost after switching the fixture off. In order to save the values to the fixture, go to DMX value of 237 and stay in it for 3 sec. The set values will be saved to the fixture and will not be lost by switching the fixture off and on.

**Reset to default** - The item sets items "Pixel Index" and "Pixel Mirror" to default (factory) values.

**Microphone Sensitivity** - Enter the menu if you want to adjust the microphone sensitivity from 1 (max.) to 20 (min.).

**Blackout Settings** - Use the menu if you need to close the light output under certain conditions which are described below

**Blackout DMC** - Blackout during movement correction. Set this option On if you wish to close light output during the time when the head goes to its correct position, which has been changed by an external force.

**Active Blackouts** - Use this menu if you wish to close the light output during effect changes.

**Pan/Tilt Moving** - The menu item enables to close light output while the pan/tilt coordinates are changing.

**White Point 8000K** - If the function is on, the CTC channel allows to set desired white in range of 8000K-2700K (0 DMX=8000K, 255 DMX=2700K). Necessary condition is , that RGBW channels have to be full or set at the same DMX values, e.g. 150.

If this function is off, the range of whites is not uniform and may be different for each fixture.

**Colour Mixing Mode** - This item allows switching into RGBW or CMY mode. In the CMY mode, the white(8bit)/white (16) bit channels are not active.

**Tungsten Effect Sim.** - This function simulates behaviour of a halogen lamp during dimming at calibrated whites 2700K, 3200K. You can select from various lamp wattage simulation: 750W, 1000W, 1200W, 2000W, 2500W.

**Dimmer Curve** - You can select desired dimmer curve: Linear or Square Law.

**LEDs Output Frequency** - The function allows you to set the PWM (Pulse Width Modulation) output frequency of LEDs to Standard (300Hz) or High (600Hz).

**LEDs Frequency Adjust** - The function allows you to change the selected PWM output frequency of LEDs in 6 levels up and down around the selected frequency in the menu "LEDs Output Frequency".

-1...-6 - Frequency levels 1 - 6 under selected frequency.

00 - Selected frequency (Standard or High)

1...6 - Frequency levels 1 - 6 above selected frequency.



**Init Effect Positions** - Use the menu to set all effects to the desired positions at which they will stay after switching the fixture on without DMX signal connected.

**Screen Settings** - Use this menu to change the touch screen settings.

**Display Intensity** - The item allows to control the intensity of the screen (1-min., 10-max.).

**Screen saver Delay** - The item allows you to keep the screen on or to turn it off automatically after 1-10 minutes after last touch (or pressing any button on the control panel).

**Touchscreen Lock** - The item allows you to lock the screen after last touch (or pressing any button on the control panel). The time delay can be set in range of 1-10 minutes. To unlock the screen, press the [ENTER/Display On] button.

**Recalibrate Touchscreen** - The item starts calibration of the touchscreen. Follow the instructions on the screen.

**Display Orientation** - The menu allows to change display orientation.

**Normal** - Standard display orientation if the fixture is placed horizontally (e.g. on the ground).

**Inverted** - This function rotates menu 180 degrees from current orientation.

**Auto** - The option activates a gravitation sensor for automatic screen orientation.

Note: **Auto** option is set as default. You change the display orientation by touching the icon  on the display, an the option set in the "Display Orientation" menu is temporarily overridden.

**Temperature unit** - Use the menu item to change temperature unit from °C to °F.

**Fan Mode** - Use the menu to set the fixture fans to max. power mode ("**High**") or to auto-control mode ("**Auto**"). The option "**Silent**" allows you to set desired fan noise. The light output of the fixture is reduced at low speeds of fans.

**Date & Time Settings** - Use this menu to set current date and time for the fixture log system (menu "View Logs"). Set this menu item before first fixture operation.

**Default Settings** - The menu item allows to set all fixture parameters to the default (factory) values.

## 7.4 Tab "Manual Control"



**Reset Functions** - The menu allows to reset the fixture either per function modules or all modules together.

**Total System Reset** - The item resets all function modules.

**Pan/Tilt Reset** - The item resets the pan and tilt movement.

**Zoom Reset** - The item resets the zoom module.

**Flower E. Reset** - The item resets the Flower effect.

**Manual Effect control** - Use the menu to control all fixture channels by means of the control panel.

## 7.5 Tab "Stand-alone"



**Test Sequences** - Use the menu to run a test/demo sequences without an external controller, which will show you some possibilities of using Robin Spiider.

**Dynamic Mode** - This mode uses all Robin Spiider functions including pan/tilt movement and therefore is good for a complete introduction of the fixture.

**Static Mode** - This mode is suitable for projections on the wall, ceiling or ground without any pan/tilt movement. Adjust the pan and tilt to desired positions and start test sequences by touching the green ► icon.

**Music Trigger** - Use the item to activate the sound control of the running program via the built-in microphone.

**Preset Playback** - This menu allows you to select the program which will be played in a loop after switching the fixture on (the option is commonly used in a stand-alone operation without an external controller).

**None** - The option disables "Presetting playback" function.

**Test** - The option starts the test sequences.

**Prog. 1** - The option starts user program No. 1.

**Prog. 2** - The option starts user program No. 2.

**Prog. 3** - The option starts user program No. 3.

**Play program** - Use the menu to run desired program in a loop.

**Play Program 1** - The option starts user program No.1.

**Play Program 2** - The option starts user program No. 2.

**Play Program 3** - The option starts user program No. 3.

**Edit Program** - Use the menu to create or to edit desired program. The Robin Spider offers 3 free programs, each up to 100 steps.

**Edit Program 1** - The option allows to edit user program No.1.

**Edit Program 2** - The option allows to edit user program No.2.

**Edit Program 3** - The option allows to edit user program No.3

To edit program:

1. Touch the item which you want to edit ("Edit Program 1" - "Edit Program 3").

2. Touch the item "Edit Program Steps".

3. Touch the item "Step 1".

4. From the list of effects touch desired effect and set its value. Browse through the list by touching the [up arrow] and [down arrow] and set all desired effects.

An item "Step Time" (value of 0-25.5 sec.) is the time during which effects last in the current step

5. Save adjusted effects to the current step by touching the [confirm] or save and copy them to the following step by touching the [confirm+copy]. By touching the text box "Preview" next to the current program step you can view created scene.

6. Repeat the steps 4 and 5 for next program steps.

7. After editing desired program steps, adjust the length of the program by touching the text boxes "Start Step" and "End Step".

Meaning of the icons used in the "Edit Program" menu:

↓ - moves down on the next page

↑ - moves up on the previous page

✓ - saves adjusted values and leaves menu

✓+ - saves values to the current step and copy them to the following prog. step

✗ - leaves menu without saving values

## 7.6 Tab "Service"



**Adjust DMX Values** - The menu allows you to set all effects to desired positions before fine calibration of the effects .

**Calibrations** - This menu enables fine calibration of fixture effects and download default calibration values.

**Calibrate Effects** - The menu allows the fine adjustment of effects.

**Pan**- a pan position fine adjustment

**Tilt** - a tilt position fine adjustment

**FE Rotation** - a fine flower effect rotation

*Calibration of the effects via the control board*

1. Disconnect DMX controller from the fixture and enter the "Calibrate Effects" menu.

2. Use the [up arrow] and [down arrow] to find "Pan" and touch it to enter the fine effect adjustment screen.

3. Set desired value and save it by touching the [confirm].

4. Repeat steps 2 and 3 for next item

5. After calibrating all effects, touch the [confirm] to save all adjusted values and reset the fixture.

**Calibrate Colours** - The menu serves for adjusting of LEDs saturation to achieve uniform colours

The items **Red, Green, Blue** and **White** serve for adjustment of white 5600K.

*Calibration of white colour 5600K via the control board:*

1. Disconnect DMX controller from the fixture , open shutter and dimmer and set the CTC channel to DMX=64 (white 5600K), RGBW channels to 255 DMX and Zoom channel to 128 DMX.

2. Set the following items in the menu Personality:  
     White Point 8000K =On  
     Colour Mixing Mode=RGBW
3. Aim the light beam on the lux meter (e.g. Minolta CL-500A Chroma meter) which is placed at min. distance of 3 m from the fixture.
4. Enter the menu Calibrate Colours.
5. By means of the Red, green, Blue and White items adjust the 5600K colour temperature as exactly as possible ( $\Delta u'v' = 0$ ).
6. After adjusting 5600K colour temperature, touch the [confirm] to save all adjusted values and reset the fixture.

The items **Red Intensity** ,**Green Intensity**, **Blue Intensity** and **White Intensity** serve for correction of intensity of red, green, blue and white colour on desired level (during fixture calibration in the factory).

**Pixel Correction** - The menu serves for colour calibration of fixture pixels in order to get uniform colours all over pixels.

Note:User can do the calibration of white 5600K only, other colour calibrations should be done in the factory.

**Calibrate Pan/Tilt EMS** - This menu item allows calibration of the pan/tilt electronic motion stabilizer. Important: during this calibration any external force must not influence the fixture and the surface at which the fixture stands (or truss if the fixture hangs) has to be without movement, shake, strokes etc.

**Load Default Calibrations** - The item loads default (factory) calibration values.

**Update software** - The menu item allows you to update software in the fixture via either serial or USB port of PC. The following items are required in order to update software:

- PC running Windows or Linux or macOS
- DSU file
- Flash cable RS232/DMX (P/N13050624) or Robe Universal Interface / Robe Universal interface WTX.

To update software in the fixture:

1. DSU file is available from Robe web site at [WWW.robe.cz](http://WWW.robe.cz).  
     File with extension zip is intended for Windows (used and tested from XP to W10 on 32/64bit systems).  
     File with extension tbz is intended for Linux (used and tested on Debian and Ubuntu 32/64bit).  
     File with extension dmg is intended for macOS (used and tested on OSX up to Sierra) XQuartz required, install it from <https://www.xquartz.org/>  
     Save the download file to a folder on your computer.  
     In case that you use windows, extract files in the zip file (e.g. DSU\_RobinSpiider\_18051835.zip)
2. Disconnect the fixture from DMX controller.
3. If you use the flash cable RS232/DMX, connect a serial port of your computer with DMX input of the fixture by means of the cable (probably you will need some USB to RS 232 converter if your computer has USB ports only).  
     If you use the Robe Universal Interface, connect a USB port of your computer with the Robe Universal Interface by means of the USB cable and DMX input of the fixture with the DMX output of the Robe Universal Interface via a DMX cable.

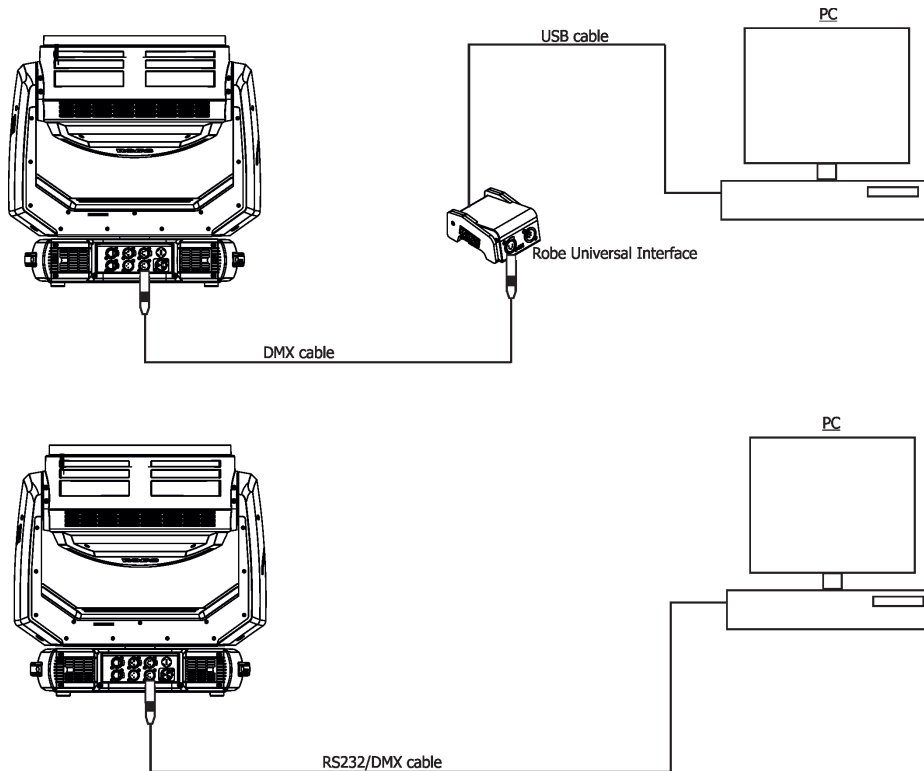

4. Switch the fixture to the update mode (Tab "Service" --> Update software).  
 Note: If you do not want to continue in the software update, you have to switch off and on the fixture to escape from the updating mode.  
 We recommend to cancel all running programs on your computer before starting the software uploader.
5. Double-click the software uploader file (e.g. DSU\_RobinSpiider\_18051835.exe) in the extracted files. The Software Uploader program will start running.

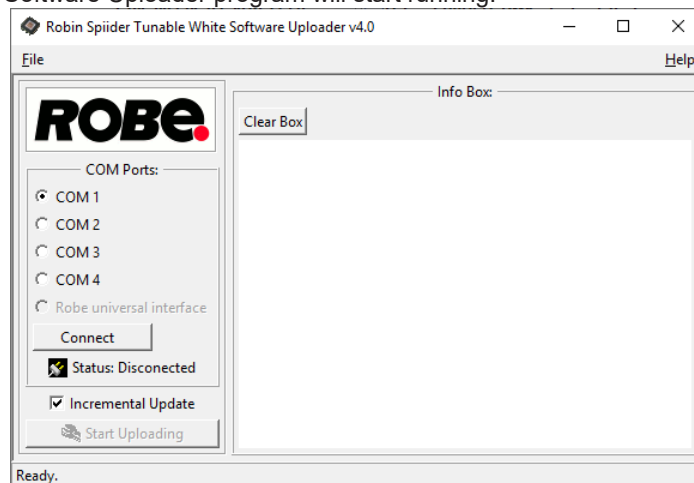

6. Select correct "COM " number if you use a Flash cable RS232/DMX or select "Robe Universal Interface 1 " if you use the Robe Universal Interface/Robe Universal Interface WTX and then click on the "Connect" button.
7. If the connection is OK, click the "Start Uploading" button to start software uploading. It will take several minutes to perform software update.  
 If the option "Incremental Update" is not checked, all processors will be updated (including processors with the same software version).  
 If you wish to update only processors with new version of software, check the "Incremental Update box".  
 Avoid interrupting the process. Update status is being displayed in the "Info Box" window.  
 When the update is finished, the line with the text "Fixture is successfully updated" will appear in this window.

Note: After all processors updating, the fixture will be set to default values. If you use the Incremental update,

setting the fixture to default values depends on type of updated processors.

In case upload process is interrupted (e.g. power loss), the fixture stays in “Updating mode” and you will have to repeat the software update again.

Another way, how to update software in the fixtures (especially large installation of fixtures) is to use the ROBE Uploader. It is a software for automatized software update of Robe fixtures. It can take advantage of RDM support and Ethernet ports if present in the units.

For more information please see <https://www.robe.cz/robe-uploader/>.

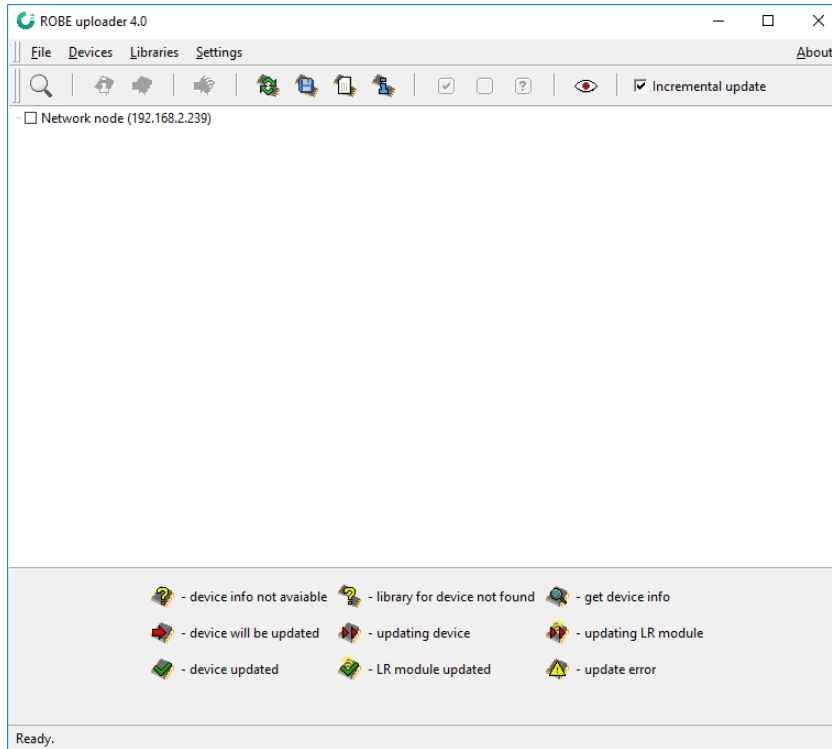

## 8. RDM

This fixture supports RDM operation. RDM (Remote Device Management) is a bi-directional communications protocol for use in DMX512 control systems, it is the new open standard for DMX512 device configuration and status monitoring.

The RDM protocol allows data packets to be inserted into a DMX512 data stream without adversely affecting existing non-RDM equipment. By using a special „Start Code,“ and by complying with the timing specifications for DMX512, the RDM protocol allows a console or dedicated RDM controller to send commands to and receive messages from specific moving lights.

RDM allows explicit commands to be sent to a device and responses to be received from it.

The list of commands for Robin Spiider is the following.

Parameter ID	Discovery command	SET command	GET command
DISC_UNIQUE_BRANCH	*		
DISC_MUTE	*		
DISC_UN_MUTE	*		
DEVICE_INFO			*
SUPPORTED_PARAMETERS			*
SOFTWARE_VERSION_LABEL			*
DMX_START_ADDRESS		*	*
IDENTIFY_DEVICE		*	*
DEVICE_MODEL_DESCRIPTION			*

MANUFACTURER_LABEL			*
DEVICE_LABEL		*	*
SENSOR_DEFINITION			*
SENSOR_VALUE			*
DISPLAY_INVERT		*	*
DISPLAY_LEVEL		*	*
PAN_INVERT		*	*
TILT_INVERT		*	*
DEVICE_RESET		*	
DMX_PERSONALITY		*	*
DMX_PERSONALITY_DESCRIPTION			*
STATUS_MESSAGES			*
STATUS_ID_DESCRIPTION			*
DEVICE_HOURS <sup>2</sup>			*
ROBE_DMX_INPUT		*	*
ROBE_WIRELESS_UNLINK		*	

<sup>2</sup>...Commands relative resetable values

RDM model ID for the Robin Spider is 0x00c5.

## 9. Error and information messages

### Information icon



#### - Air Filters Cleaning

This icon signals that cleaning period of the air filters has elapsed and you have to clear air filters and reset the menu item "Elapsed Time".

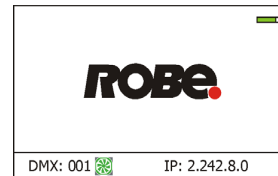

### Errors

Error in the fixture is signalled by the yellow warning icon at the bottom line of the screen:



Touch the warning icon or press the [ESCAPE] button to display error messages.

List of error and information messages:

#### **Temper.Sensor Error**

The message informs you that the communication between the head temperature sensor and the main processor failed.

#### **Tilt Error 1 (Tilt Error 2)**

This message will appear after the reset of the fixture if the head's magnetic-indexing circuit malfunctions (sensor failed or magnet is missing) or the stepping motor is defective or its driving IC on the PCB. The head is not located in the default position after the reset.

#### **Pan Error 1 (Pan Error 2)**

This message will appear after the reset of the fixture if the yoke's magnetic-indexing circuit malfunctions (sensor failed or magnet is missing) or the stepping motor is defective or its driving IC on the PCB. The yoke is not located in the default position after the reset of the fixture.

#### **Zoom Error 1 (Zoom Error 2)**

The messages will appear after the reset of the zoom module if the zoom module is not located in the default position.

#### **Rod Error**

The messages will appear after the reset of the flower effect if the rod is not in the default position.

#### **EEprom Error**

Hardware error of the EEPROM.

#### **Recharge The battery**

The battery on the display board needs to be charged. Let the fixture on for cca 6 hrs.

#### **Battery faulty. Replace it.**

The battery on the display board is exhausted and should be replaced immediately.

#### **Pan/Tilt EMS Cal. Error**

The EMS system is not calibrated.

#### **Pan/Tilt EMS Error**

Control electronics cannot communicate with the EMS system.

#### **Clean Air Filters**

The message informs that the item "Elapsed Time" in the "Fixture Information" menu is at 0 value. Clean air filters and reset this counter.

## 10. Technical Specifications

### Electrical

Power supply:.....electronic auto-ranging  
Input voltage range:..... 100-240V, 50-60Hz  
Fuse:.....T 8 A  
Max. power consumption .....660W ( power factor= 0.99)

### Optic

Light source: 19 RGBW LED multichips  
RGBW or CMY colour mixing  
19 controllable LED multichips (pixels)  
LED life expectancy: min. 50.000 hours

### Virtual colour wheel

66 preset colours  
CTC in range of 2700K-8000K  
Halogen lamp effect at whites 2700K and 3200K  
Rainbow effect with in both directions with variable speed

### Zoom

Linear motorized zoom  
Min. beam angle: 4° (1/2 beam)  
Max. beam angle: 50°(1/10 beam)

### Effect

Flower effect rotating in both directions  
10 Flower effect macros

### Strobe

Strobe effect with variable speed (0.3 - 20Hz)

### Dimmer

Smooth dimmer from 0 - 100 %

### Control

Graphic touch screen for fixture setting and addressing  
Gravitation sensor for auto screen positioning  
Battery backup of the touch screen  
Readout fixture and LED module usage, receiving DMX values, temperatures, etc  
Built-in analyzer for easy fault finding, error messages  
Built-in demo sequences  
Individual pixel control of each LED  
Stand-alone operation  
3 user editable programs, each up to 100 steps  
Supported protocols: USITT DMX 512, RDM, ArtNet, MANet, MANet2, sACN, Kling-Net  
Support of RDM (Remote Device Management)  
10 DMX modes (49, 27, 33, 90, 27,47, 91,110,104,123 control channels)

### Wireless DMX/RDM module (only for Wireles DMX version)

Compliance with USITT DMX-512 (1986 & 1990) and 512-A  
Full DMX fidelity and frame integrity  
Auto sensing of DMX frame rate and frame size  
<5ms DMX latency  
Operational frequency range of 2402-2480 MHz  
Producer: LumenRadio



**Pan/Tilt**

Pan movement range 540°  
Tilt movement range 220°  
Continual pan/tilt rotation  
16 bit movement resolution  
Pan/Tilt electronic motion stabilizer  
Automatic Pan/Tilt position correction  
Remotely controllable speed of pan/tilt movement for easy programming  
Pan/tilt-lock mechanism

**Connection**

DMX data in/out: Locking 3-pin and 5-pin XLR  
AC power IN: Neutrik TrueOne NAC3MPX  
Ethernet IN/Out: RJ45

**Max. number of fixtures in Ethernet IN/Out line**

8

**Rigging**

Mounting points: 2 pairs of 1/4-turn locks  
Mounting horizontally or vertically via two Omega brackets

**Temperatures**

Maximum ambient temperature : 45° C  
Maximum housing temperature : 75° C

**Minimum distances**

Min. distance from flammable surfaces: 0.5 m  
Min. distance to lighted object: 1 m

**Total heat dissipation**

Max.1688 BTU/hr

**Ingress protection**

IP2x

**Accessories**

1 x Omega adapter CL-regular 2 pcs in box (P/N 10980033)  
1 x power cable

**Weight (net)**

13.25 kg

## Dimensions (mm)

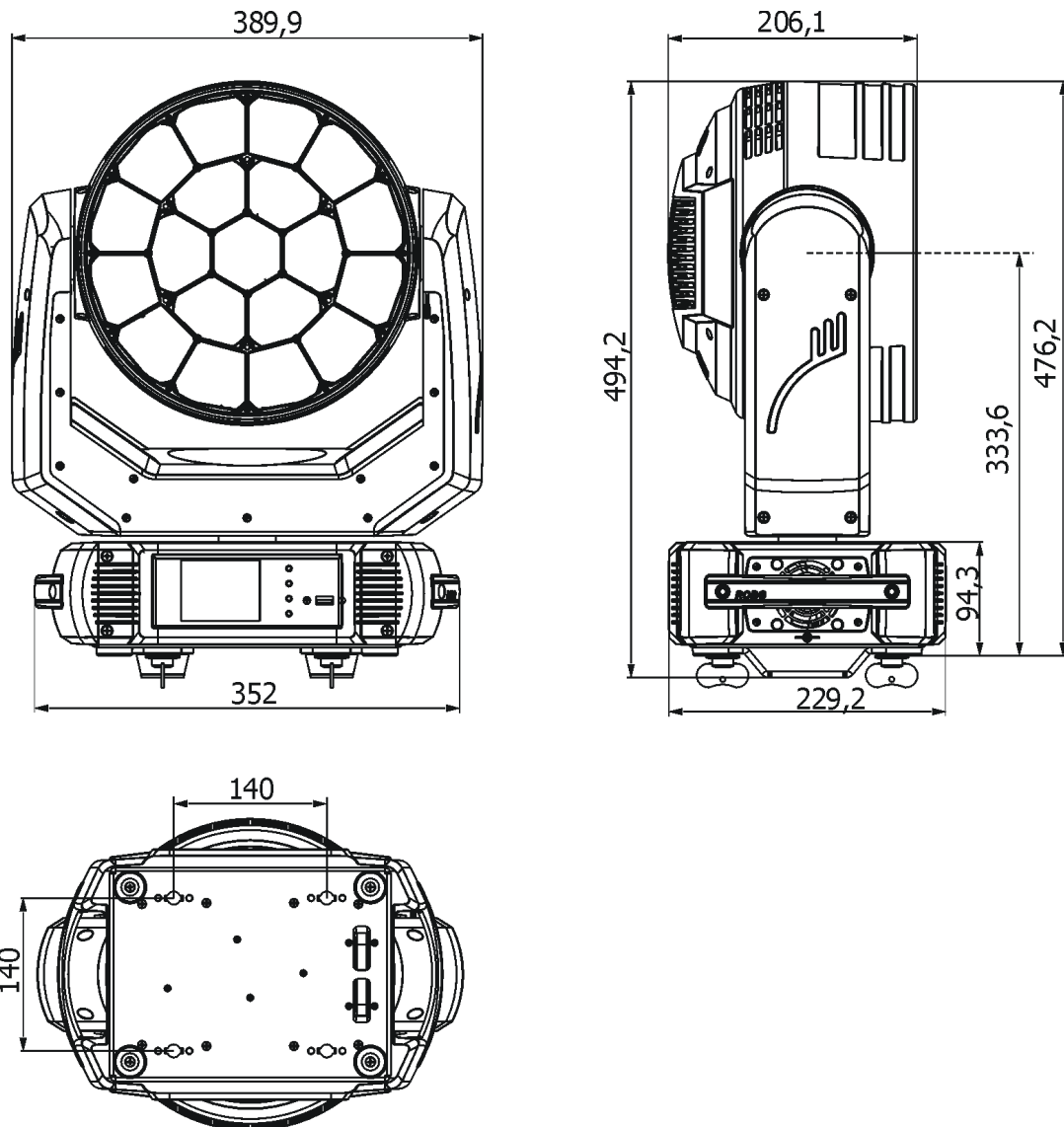

## Optional accessories

- Upgrade kit CRMX Universal 260 (P/N 99030100)
- EggCrate for Robin Spider (P/N10980317)
- Diffuser 2° for Robin Spider (P/N 10980416)
- Doughty Trigger Clamp (P/N 17030386)
- Safety wire 35 kg (P/N 99011963)
- Clear lens cover Spider (P/N 10980607)

## 11. Maintenance and cleaning

It is absolutely essential that the fixture is kept clean and that dust, dirt and smoke-fluid residues must not build up on or within the fixture. Otherwise, the fixture's light output will be significantly reduced. Regular cleaning will not only ensure the maximum light output, but will also allow the fixture to function reliably throughout its life. A soft lint-free cloth moistened with any weak detergent solution is recommended for cleaning fixture's covers, under no circumstances should alcohol or solvents be used!

**DANGER !**  
**Disconnect from the mains before starting any  
maintenance and cleaning work**

The interior of the fixture should be cleaned at least annually using a vacuum cleaner or compressed air. The cooling fans should be cleaned at least twice a year.

**Important! Never use alcohols (ethanol, methanol, isopropyl alcohol), acetone and another aggressive solvents for cleaning the front lens array.  
Do not immerse lenses in liquid (e.g. water) during cleaning.**

Recommended steps for cleaning the front lens array:

1. Use low-pressure compressed air to remove coarse dust from lenses.
2. Use distilled water with weak detergent solution and lint-free small cloth for further cleaning of lenses.
3. Use an antistatic, alcohol-free screen cleaner (we recommend the Lyreco Screen Cleaner) and polish lenses until they are dry.
4. Check the lenses are dry before reapplying power.

Note: potential foggy front lens array does not influence function of the fixture and does not subject to complaint

**Check the air filter periodically and clean before they become clogged!**

Periodically clean air filter placed in the fixture's base. The air filter cover is fastened by means of magnets. Use a vacuum cleaner, compressed air or you can wash them and put back dry. After replacing the air filters, reset the elapsed time counter in the menu "Information" (Information--->Air Filters--->Elapsed Time).

### Replacing the fuse.

Before replacing the fuse, unplug mains lead.

1. Remove the fuse holder on the rear panel of the base with a fitting screwdriver from the housing (anti-clockwise).
2. Remove the old fuse from the fuse holder.
3. Install the new fuse in the fuse holder (only the same type and rating).
4. Replace the fuseholder in the housing and fix it.

### Checking plastic parts of the fixture.

The plastic parts of the fixture should be checked for damages and beginning cracks at least every two months. If hint of a crack is found on some plastic part, do not use the fixture until the damaged part will be replaced. Cracks or another damages of the plastic parts can be caused by the fixture transportation or manipulation and also ageing process may influence plastic materials.

This checking is necessary for both fixed installations and preparing fixtures for renting. Any free moving parts inside of the fixture head, cracked plastic or any plastic part not sitting properly in place need to be immediately replaced.

Example of cracks in the plastic parts of the fixture (for illustrative purposes).

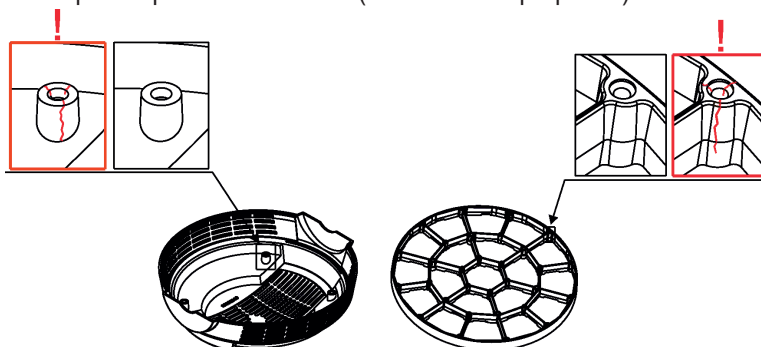

## 11.1 Removing the optical module

*The following instructions are intended for service purposes only.*

### To remove the optical module

1. Disconnect the fixture from mains.
2. Loosen the four fastening screws (2) on each side of the head covers (1) to remove the covers.
3. Loosen the four fastening screws (4) on back cover of the head (3)
4. Unscrew the securing screw (5) from the guide-pin. Its position is shown on the picture (the fan connecting PCB (6) has to be on the right from the securing screw (5)).

If you do not have access to the securing screw, push the optical module (7) towards the fans. Do not touch the plastic lenses bare hands.

**DO NOT FORGET TO UNSCREW THIS SECURING SCREW (5)!**

5. Carefully take the optical module (7) out of the guide-tubes (11) and motors (10).

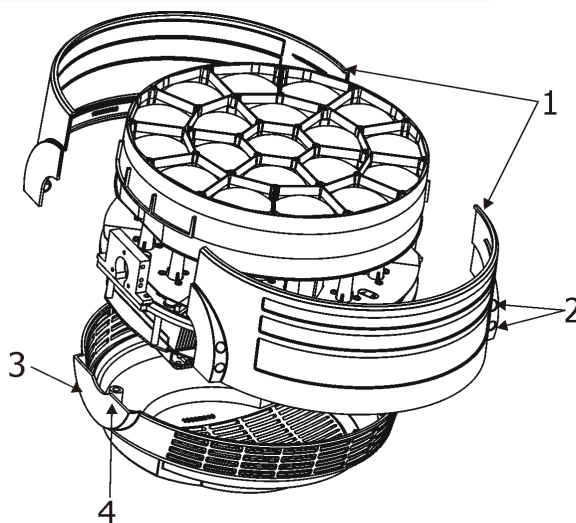

### To insert the optical module back

1. Connect the fixture to mains and after fixture reset go to tab Manual Control, select item Zoom and set it at 255 DMX.

2. Put the optical module (7) on the LED module (12) in such a way that three guide-pins (8) aim into guide-tubes (11) and three lead screws (9) aim into motors (10).

3. Hold the optical module in this position and slowly change the item Zoom from 255 DMX to 0 DMX. Motors "draw" the optical module to the LED module (12).

**DO NOT TRY TO INSERT THE OPTICAL MODULE BY A FORCE.**

4. Run the Zoom Reset from tab Manual Control or disconnect/connect the fixture to mains.

5. Disconnect the fixture from mains.

6. Screw the securing screw (5) back to the guide-pin. **DO NOT FORGET TO SCREW THIS SECURING SCREW (5)!**

7. Screw covers on the fixture head.

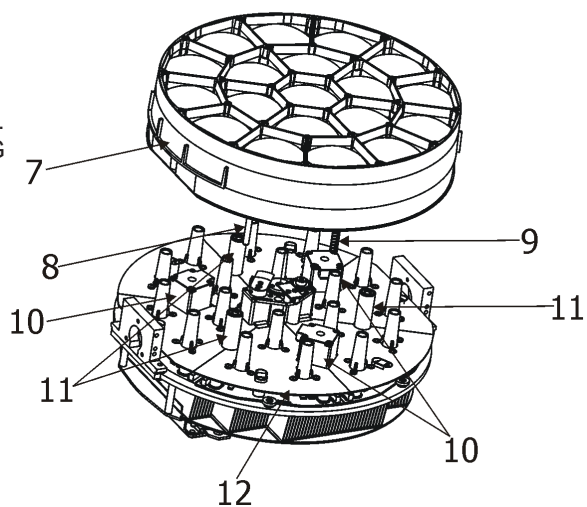
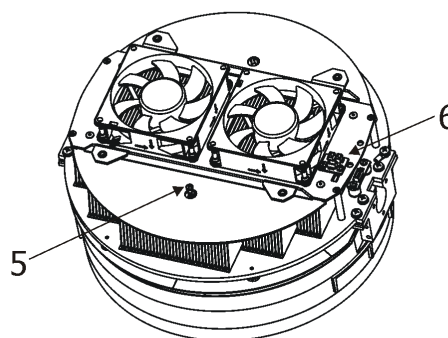

## 11.2 Disposing of the product

To preserve the environment please dispose or recycle this product at the end of its life according to the local regulations and codes.

## 12. ChangeLog

This section summarizes all types of changes in the user manual.

Version of the manual	Date of issue	Description of changes
1.1	16/12/2016	DMX protocol ver. 1.3 (added 6 DMX modes)
1.2	24/01/2017	Added Eggcrate installation
1.3	10/02/2017	DMX protocol ver. 1.4 (Pattern crossfade channel added)
1.4	27/02/2017	DMX protocol ver.1.5
1.5	24/03/2017	DMX protocol ver.1.6
1.6	20/10/2017	DMX protocol 1.7 (Parking position, Pixel index, Pixel mirror on Power ch.)
1.7	1/11/2017	Item Pixel control added to menu Personality
1.8	7/11/2017	DMX protocol 1.8 (Saving Pixel Index and pixel mirror to fixture)
1.9	07/12/2017	2° Diffuser added to Optional Accessories
2.0	15/01/2018	Optional accessories changed
2.1	20/03/2018	Installation of the diffuser added
2.2	26/04/2018	DMX protocol 1.9
2.3	03/06/2019	DMX protocol 2.0 (Leds PWM output frequency added on Power channel )
2.4	03/07/2019	Check of plastic added (chapter Maintenance and cleaning)
2.5	18/09/2019	DMX protocol 2.1 (RoboSpot support added)
2.6	11/11/2019	Description of lenses cleaning added
2.7	18/04/2020	DMX protocol v. 2.2 (pixel effects modified)
2.8	28/07/2020	DMX protocol v. 2.3 (silent mode added)
2.9	15/10/2020	Added information about foggy lens array
3.0	24/06/2021	BTU/h value changed
3.1	28/01/2022	Number of fixtures in Ethernet IN-OUT line changed at 8.
3.2	19/01/2022	Diffuser installation changed
3.3	02/03/2023	Pixel calibration added

### 13. Photometric diagrams

#### Min. Zoom

Total Output: 5500 lumens

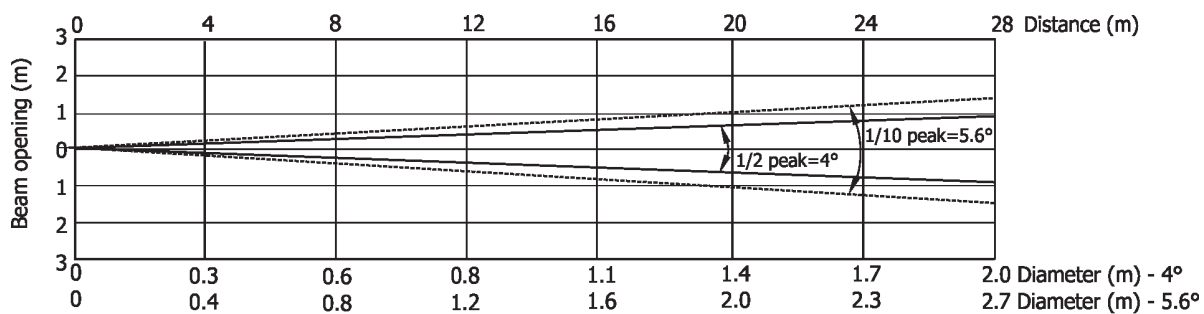

Distance (m)	4	5	8	12	16	20	24	28	
Red	14560/1353	9320/866	3640/338	1618/150	910/85	582/54	405/38	297/28	Intensity (center) Lux/Footcandles
Green	25500/2369	16320/1516	6375/592	2833/263	1594/148	1020/95	708/66	520/48	
Blue	4922/457	3150/293	1230/114	547/51	308/29	197/18	137/13	100/9	
White	35031/3254	22420/2082	8757/814	3892/362	2190/203	1400/130	967/90	714/44	
R+G+B+W	78280/7273	50100/4654	19570/1818	8698/808	4893/455	3130/291	2175/202	1598/148	

#### Illuminance distribution

Distance=5m

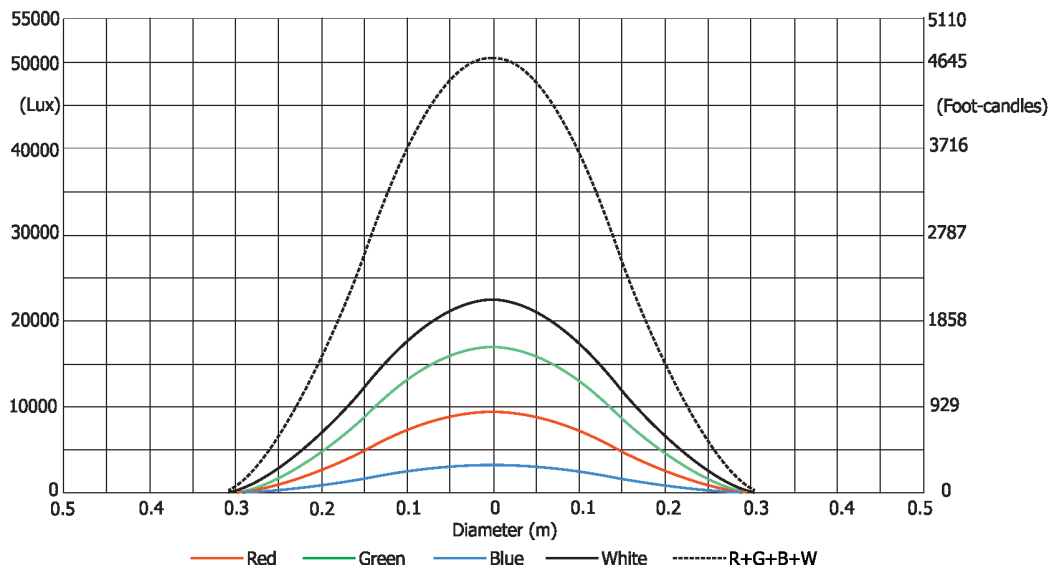

## Max. Zoom

Total Output: 11000 lumens

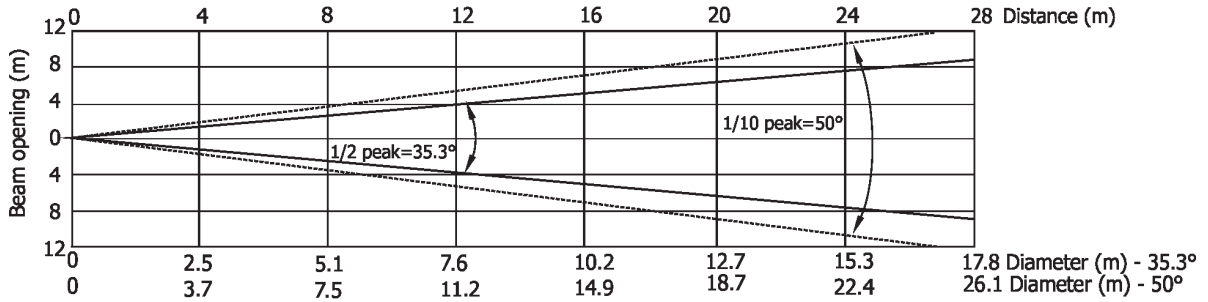

Distance (m)	4	5	8	12	16	20	24	28	
Red	367/34	235/22	92/9	40/4	23/2	15/1.4	10/0.9	8/0.7	Intensity (center) Lux/Footcandles
Green	656/61	420/39	164/15	73/7	41/3.8	26/2.4	18/1.7	13/1.2	
Blue	133/12	85/8	33/3	15/1.4	8/0.8	5/0.5	4/0.3	2.7/0.3	
White	890/83	570/53	222/21	99/9	56/5	36/3.3	25/2.3	18/1.7	
R+G+B+W	1953/182	1250/116	488/45	217/20	122/11	78/7	54/5	40/3.7	

## Illuminance distribution

Distance=5m

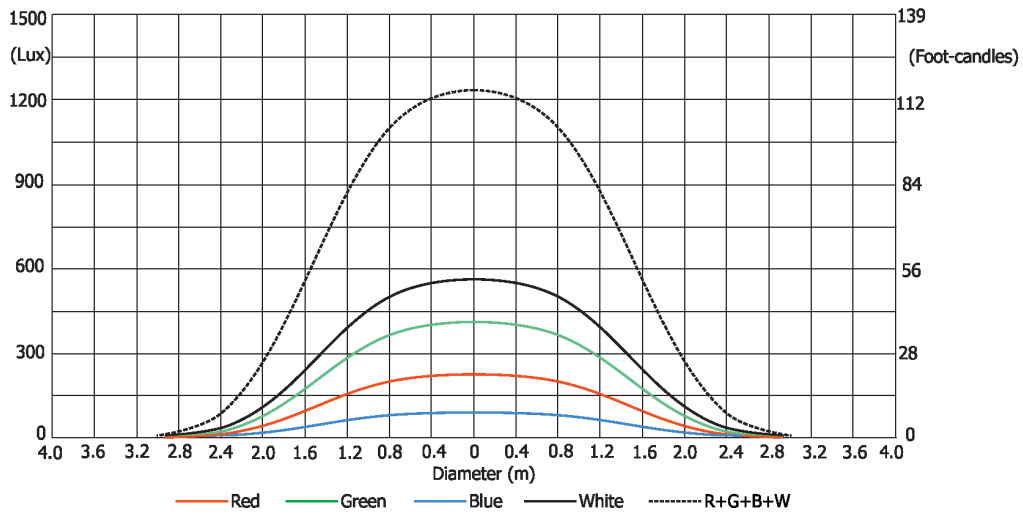

March 3, 2023

Copyright © 2016-2023 Robe Lighting - All rights reserved

All Specifications subject to change without notice

Made in CZECH REPUBLIC by ROBE LIGHTING s.r.o. Palackeho 416/20 CZ 75701 Valasske Mezirici



## 14. Appendix - DMX modes overview

Pixel modes underlined

Mode	DMX Channels	Main Features
<b>Mode 1</b>	49	16-bit pan/tit Control of three rings separately 16-bit control of four colours (R,G,B,W) on each LED ring 16-bit Dimmer Pixel effect control (shape,speed, fade) Flower effect control Without control of individual pixels
<b>Mode 2</b>	27	16-bit pan/tit Circle active zone 8-bit control of four colours (R,G,B,W) and Dimmer Pixel effect control (shape,speed, fade) Flower effect control Without control of individual pixels
<b>Mode 3</b>	33	16-bit pan/tit Circle active zone 16-bit control of four colours (R,G,B,W) and Dimmer Pixel effect control (shape,speed, fade) Flower effect control Without control of individual pixels
<b><u>Mode 4</u></b>	90	16-bit pan/tit Circle active zone 16-bit control of four individual colours (R,G,B,W) and Dimmer Pixel effect control (shape,speed, fade) Flower effect Individual pixels control (R,G,B)
<b>Mode 5</b>	27	16-bit pan/tit Selection of active zone (rings, sectors) 8-bit control of four individual colours (R,G,B,W) and Dimmer Flower effect control Without control of individual pixels.
<b>Mode 6</b>	47	16-bit pan/tit Selection of active zone (rings, sectors) 16-bit control of four individual colours (R,G,B,W) and Dimmer Pixel patterns control (shape, repeat/size, rotation, transition, fade, crossfade, colour) Flower effect control Without control of individual pixels
<b><u>Mode 7</u></b>	91	16-bit pan/tit Selection of active zone (rings, sectors) 16-bit control of four individual colours (R,G,B,W) and Dimmer Flower effect control Individual control of pixels (R,G,B)
<b><u>Mode 8</u></b>	110	16-bit pan/tit Selection of active zone (rings, sectors) 16-bit control of four individual colours (R,G,B,W) and Dimmer Flower effect control Individual control of pixels (R,G,B,W)
<b><u>Mode 9</u></b>	104	16-bit pan/tit Selection of active zone (rings, sectors) 16-bit control of four individual colours (R,G,B,W) and Dimmer Pixel patterns control (shape, repeat/size, rotation, transition, fade, crossfade, colour) Flower effect control Individual control of pixels (R,G,B)
<b><u>Mode 10</u></b>	123	16-bit pan/tit Selection of active zone (rings, sectors) 16-bit control of four individual colours (R,G,B,W) and Dimmer Pixel patterns control (shape, repeat/size, rotation, transition, fade, crossfade, colour) Flower effect control Individual control of pixels (R,G,B,W)



DMX protocol

Robin SPIIDER - DMX protocol							
Version: 2.3 (10 modes) <b>Mode 1</b> - 3-zones, <b>Mode 2</b> -Basic, <b>Mode 3</b> -Advanced, <b>Mode 4</b> -Full RGBW							
Mode/channel				DMX Value	Function	Type of control	
1	2	3	4				
1	1	1	1		<b>Pan (8 bit)</b>		
				0 - 255	Pan movement by 540° (128=default)	proportional	
2	2	2	2		<b>Pan Fine (16 bit)</b>		
				0 - 255	Fine control of pan movement (0=default)	proportional	
3	3	3	3		<b>Tilt (8 bit)</b>		
				0 - 255	Tilt movement by 220° (128=default)	proportional	
4	4	4	4		<b>Tilt fine (16 bit)</b>		
				0 - 255	Fine control of tilt movement (0=default)	proportional	
5	5	5	5		<b>Pan/Tilt speed , Pan/Tilt time</b>		
				0	Standard mode (0=default)	step	
				1	Max. Speed Mode	step	
					<b>Pan/Tilt speed mode</b>		
				2 - 255	Speed from max. to min.	proportional	
					<b>Pan/Tilt time mode</b>		
				2 - 255	Time from 0.2 s to 25.5 sec.	proportional	
6	6	6	6		<b>Power/Special functions</b>		
				0 - 9	Reserved (0=default)		
					<i>To activate following functions, stop in DMX value for at least 3 s and shutter must be closed at least 3 sec. („Shutter,Strobe“ channel 53/27/31/31 must be at range: 0-31 DMX). Corresponding menu items are temporarily overridden (unless otherwise stated)</i>		
				10-14	DMX input: Wired DMX	step	
				15-19	DMX input: Wireless DMX *	step	
				20-24	Graphic display ON	step	
				25-29	Graphic display OFF	step	
				30-34	RGBW colour mixing mode	step	
				35-39	CMY colour mixing mode	step	
				40-44	Pan/Tilt speed mode	step	
				45 - 49	Pan/Tilt time mode	step	
				50 -54	Blackout while pan/tilt moving	step	
				55 -59	Disabled blackout while pan/tilt moving	step	
				60 - 64	Dimmer curve-square law	step	
				65 - 69	Dimmer curve-linear	step	
				70 - 74	Fans mode: Auto	step	
				75 - 79	Fans mode: High	step	
				80-84	White point 8000K ON	step	
				85-89	White point 8000K OFF	step	
				90 -109	Reserved		
				110-114	Kling-Net On	step	
				115-119	Kling-Net Off	step	
				120-124	Parking position On	step	
				125-129	Parking position Off	step	
					<i>To activate following functions, stop in DMX value for at least 3 seconds (except function Pixel index and Pixel Mirror). Corresponding menu items are temporarily overridden</i>		

## DMX protocol

				130 - 139	Fixture reset (except pan/tilt)	
				140 - 149	Pan/Tilt reset	step
				150 - 159	Zoom reset	step
				160 - 169	Flower effect reset	step
				170-171	Tungsten effect simulation (750W) On **	step
				172-173	Tungsten effect simulation (1000W) On **	step
				174-175	Tungsten effect simulation (1200W) On **	step
				176-177	Tungsten effect simulation (2000W) On **	step
				178-179	Tungsten effect simulation (2500W) On **	step
				180-181	Tungsten effect simulation Off	step
				182-184	Reserved	
				185	PWM output frequency of LEDs: Standard (300Hz)****	step
				186	PWM output frequency of LEDs: High (600Hz)****	step
					**** You can adjust selected frequency in 6 steps Up or Down around selected frequency - see table below . Default value of PWM frequency set in the fixture is Standard.	
				187	LED Frequency (step -6)	step
				188	LED Frequency (step -5)	step
				189	LED Frequency (step -4)	step
				190	LED Frequency (step -3)	step
				191	LED Frequency (step -2)	step
				192	LED Frequency (step -1)	step
				193	LED Frequency (Standard or High)	step
				194	LED Frequency (step +1)	step
				195	LED Frequency (step +2)	step
				196	LED Frequency (step +3)	step
				197	LED Frequency (step +4)	step
				198	LED Frequency (step +5)	step
				199	LED Frequency (step +6)	step
				200 - 209	Total fixture reset	step
				210 - 221	Pixel index	proportional
				222 - 223	Pixel mirror On	step
				224 - 225	Pixel mirror Off	step
				226 - 236	Reserved	
				237	Save Pixel index and mirror to fixture	step
					The following RoboSpot related commands are only applicable when the RoboSpot is connected:	
				238 - 239	RoboSpot enabled	step
				240 - 241	RoboSpot disabled - except handle faders and pan/tilt	step
				242 - 243	RoboSpot fully disabled	step
				244	Disabled "Silent mode"	step
				245 - 255	Silent mode - fan noise control from min. to max.	proportional
<b>7</b>	<b>7</b>	<b>7</b>	<b>7</b>		<b>Virtual colour wheel</b>	
				0	No function (0=default)	step
				1-2	Filter 4 (Medium Bastard Amber)	step
				3-4	Filter 25 (Sunset Red)	step
				5-6	Filter 19 (Fire)	step
				7-8	Filter 26 (Bright Red)	step
				9-10	Filter 58 (Lavender)	step
				11-12	Filter 68 (Sky Blue)	step
				13-14	Filter 36 (Medium Pink)	step

## DMX protocol

			15-16	Filter 89 (Moss Green)	step
			17-18	Filter 88 (Lime Green)	step
			19-20	Filter 90 (Dark Yellow Green)	step
			21-22	Filter 49 (Medium Purple)	step
			23-24	Filter 52 (Light Lavender)	step
			25-26	Filter 102 (Light Amber)	step
			27-28	Filter 103 (Straw)	step
			29-30	Filter 140 (Summer Blue)	step
			31-32	Filter 124 (Dark Green)	step
			33-34	Filter 106 (Primary Red)	step
			35-36	Filter 111 (Dark Pink)	step
			37-38	Filter 115 (Peacock Blue)	step
			39-40	Filter 126 (Mauve)	step
			41-42	Filter 117 (Steel Blue)	step
			43-44	Filter 118 (Light Blue)	step
			45-46	Filter 122 (Fern Green)	step
			47-48	Filter 182 (Light Red)	step
			49-50	Filter 121 (Filter Green)	step
			51-52	Filter 128 (Bright Pink)	step
			53-54	Filter 131 (Marine Blue)	step
			55-56	Filter 132 (Medium Blue)	step
			57-58	Filter 134 (Golden Amber)	step
			59-60	Filter 135 (Deep Golden Amber)	step
			61-62	Filter 136 (Pale Lavender)	step
			63-64	Filter 137 (Special Lavender)	step
			65-66	Filter 138 (Pale Green)	step
			67-68	Filter 798 (Chrysalis Pink)	step
			69-70	Filter 141 (Bright Blue)	step
			71-72	Filter 147 (Apricot)	step
			73-74	Filter 148 (Bright Rose)	step
			75-76	Filter 152 (Pale Gold)	step
			77-78	Filter 154 (Pale Rose)	step
			79-80	Filter 157 (Pink)	step
			81-82	Filter 143 (Pale Navy Blue)	step
			83-84	Filter 162 (Bastard Amber)	step
			85-86	Filter 164 (Flame Red)	step
			87-88	Filter 165 (Daylight Blue)	step
			89-90	Filter 169 (Lilac Tint)	step
			91-92	Filter 170 (Deep Lavender)	step
			93-94	Filter 172 (Lagoon Blue)	step
			95-96	Filter 194 (Surprise Pink)	step
			97-98	Filter 180 (Dark Lavender)	step
			99-100	Filter 181 (Congo Blue)	step
			101-102	Filter 197 (Alice Blue)	step
			103-104	Filter 201 (Full C.T. Blue)	step
			105-106	Filter 202 (Half C.T. Blue)	step
			107-108	Filter 203 (Quarter C.T. Blue)	step
			109-110	Filter 204 (Full C.T. Orange)	step
			111-112	Filter 219 (Fluorescent Green)	step
			113-114	Filter 206 (Quarter C.T. Orange)	step

DMX protocol

				115-116	Filter 247 (Filter Minus Green)	step
				117-118	Filter 248 (Half Minus Green)	step
				119-120	Filter 281 (Three Quarter C.T. Blue)	step
				121-122	Filter 285 (Three Quarter C.T. Orange)	step
				123-124	Filter 352 (Glacier Blue)	step
				125-126	Filter 353 (Lighter Blue)	step
				127-128	Filter 507 (Madge)	step
				129-130	Filter 778 (Millennium Gold)	step
				131-132	Filter 793 (Vanity Fair)	step
				133-235	Raw DMX	proportional
				236-245	Rainbow effect (with fade time) from slow-> fast	proportional
				246-255	Rainbow effect (without fade time) from slow-> fast	proportional
*	8	8	8		<b>Red/Cyan (8 bit)- all pixels***</b>	
				0 - 255	Colour saturation control - coarse 0-100% (255=default)	proportional
*	*	9	9		<b>Red/Cyan (16bit)- all pixels***</b>	
				0 - 255	Colour saturation control - fine (255=default)	proportional
*	9	10	10		<b>Green/Magenta (8 bit) - all pixels ***</b>	
				0 - 255	Colour saturation control - coarse 0-100% (255=default)	proportional
*	*	11	11		<b>Green/Magenta (16bit) - all pixels***</b>	
				0 - 255	Colour saturation control - fine (255=default)	proportional
*	10	12	12		<b>Blue/Yellow (8 bit) - all pixels ***</b>	
				0 - 255	Colour saturation control - coarse 0-100% (255=default)	proportional
*	*	13	13		<b>Blue/ Yellow (16bit) -all pixels***</b>	
				0 - 255	Colour saturation control - fine (255=default)	proportional
*	11	14	14		<b>White (8 bit) - all pixels</b>	
					<i>If RGBW mode is selected:</i>	
				0-255	Colour saturation control - coarse 0-100% (255=default)	proportional
					<i>If CMY mode is selected:</i>	
				0 - 255	No function	
*	*	15	15		<b>White (16 bit) - all pixels</b>	
				0 - 255	Colour saturation control - fine (255=default)	proportional
8	*	*	*		<b>Red/Cyan (8 bit) - zone 1***</b>	
				0 - 255	Colour saturation control - coarse 0-100% (255=default)	proportional
9	*	*	*		<b>Red/Cyan (16bit)- zone 1***</b>	
				0 - 255	Colour saturation control - fine (255=default)	proportional
10	*	*	*		<b>Green/Magenta (8 bit) - zone 1***</b>	
				0 - 255	Colour saturation control - coarse 0-100% (255=default)	proportional
11	*	*	*		<b>Green/Magenta (16bit)- zone 1***</b>	
				0 - 255	Colour saturation control - fine (255=default)	proportional
12	*	*	*		<b>Blue/Yellow (8 bit) - zone 1***</b>	
				0 - 255	Colour saturation control - coarse 0-100% (255=default)	proportional
13	*	*	*		<b>Blue/Yellow (16bit)- zone 1***</b>	
				0 - 255	Colour saturation control - fine (255=default)	proportional
14	*	*	*		<b>White (8 bit) - zone 1</b>	
					<i>If RGBW mode is selected:</i>	
				0-255	Colour saturation control - coarse 0-100% (255=default)	proportional
					<i>If CMY mode is selected:</i>	
				0 - 255	No function	
15	*	*	*		<b>White (16 bit) - zone 1</b>	
				0 - 255	Colour saturation control - fine (255=default)	proportional

DMX protocol

16	*	*	*	0 - 255	<b>Red/Cyan (8 bit) - zone 2***</b> Colour saturation control - coarse 0-100% (255=default)	proportional
17	*	*	*	0 - 255	<b>Red/Cyan (16bit)- zone 2***</b> Colour saturation control - fine (255=default)	proportional
18	*	*	*	0 - 255	<b>Green/Magenta (8 bit) - zone 2***</b> Colour saturation control - coarse 0-100% (255=default)	proportional
19	*	*	*	0 - 255	<b>Green/Magenta (16bit)- zone 2***</b> Colour saturation control - fine (255=default)	proportional
20	*	*	*	0 - 255	<b>Blue/Yellow (8 bit) - zone 2***</b> Colour saturation control - coarse 0-100% (255=default)	proportional
21	*	*	*	0 - 255	<b>Blue/Yellow (16bit)- zone 2***</b> Colour saturation control - fine (255=default)	proportional
22	*	*	*	0-255 0 - 255	<b>White (8 bit) - zone 2</b> <i>If RGBW mode is selected:</i> Colour saturation control - coarse 0-100% (255=default) <i>If CMY mode is selected:</i> No function	proportional
23	*	*	*	0 - 255	<b>White (16 bit) - zone 2</b> Colour saturation control - fine (255=default)	proportional
24	*	*	*	0 - 255	<b>Red/Cyan (8 bit) - zone 3***</b> Colour saturation control - coarse 0-100% (255=default)	proportional
25	*	*	*	0 - 255	<b>Red/Cyan (16bit)- zone 3***</b> Colour saturation control - fine (255=default)	proportional
26	*	*	*	0 - 255	<b>Green/Magenta (8 bit) - zone 3***</b> Colour saturation control - coarse 0-100% (255=default)	proportional
27	*	*	*	0 - 255	<b>Green/Magenta (16bit)- zone 3***</b> Colour saturation control - fine (255=default)	proportional
28	*	*	*	0 - 255	<b>Blue/Yellow (8 bit) - zone 3***</b> Colour saturation control - coarse 0-100% (255=default)	proportional
29	*	*	*	0 - 255	<b>Blue/Yellow (16bit)- zone 3***</b> Colour saturation control - fine (255=default)	proportional
30	*	*	*	0-255 0 - 255	<b>White (8 bit) - zone 3</b> <i>If RGBW mode is selected:</i> Colour saturation control - coarse 0-100% (255=default) <i>If CMY mode is selected:</i> No function	proportional
31	*	*	*	0 - 255	<b>White (16 bit) - zone 3</b> Colour saturation control - fine (255=default)	proportional
32	12	16	16	0-255	<b>CTC</b> <i>If function "White Point 8000K" is ON</i> Col. temperature correction from 8000K to 2700K -for whites only (0=8000K, 64=5600K, 128=4200K, 192=3200K, 255=2700K) To get colour temperatures stated above, RGBW channels have to be set at the same value (e.g. 255DMX) or RGB=0 and White channel > 0 DMX (0=default) (To activate Tungsten effect at 2700K and 3200K , set DMX value at "Power/Special functions" channel) <i>If function "White Point 8000K" is OFF</i> Colour temperature correction from cool col. to warm colours	proportional
33	13	17	17		<b>Colour Mix control</b>	

DMX protocol

					<i>The channel defines relation between color channels</i>	
					<b><i>IF Flower effect is active, its colour channels always have priority!</i></b>	
					<i>Global = Global Colours (RGBW, Virtual Colour Wheel)</i>	
					<i>Pixel = Pixel Colours (RGB individual pixels or Kling-Net)</i>	
				0-9	Global colours (Global has priority)	
				10-19	Maximum mode (highest values have priority)	step
				20-29	Minimum mode (lowest values have priority)	step
				30-39	Multiply mode (multiply Global and Pixel)	step
				40-49	Addition mode (Global + Pixel) (45=default)	step
				50-59	Subtraction mode (Global – Pixel)	step
				60-69	Inverted Subtraction mode (Pixel – Global)	step
				70-79	Coloured background	step
				80-127	Raw DMX	proportional
				128	Global colours only (Global has priority)	step
				129-254	Crossfade (crossfade between Global and Pixel)	proportional
				255	Pixel colours (Pixel has priority)	step
<b>34</b>	<b>14</b>	<b>18</b>	<b>18</b>		<b>Pixel effects</b>	
				0-2	No function (0=default)	
				3-4	Effect 1	step
				5-6	Effect 2	step
				:	:	:
				181-182	Effect 90	step
				183-255	Raw DMX	proportional
<b>35</b>	<b>15</b>	<b>19</b>	<b>19</b>		<b>Pixel effects speed</b>	
				0-127	Speed from min. to max. (0=default)	proportional
				128-255	Speed from max. to min. (opposite direction)	proportional
<b>36</b>	<b>16</b>	<b>20</b>	<b>20</b>		<b>Pixel effects fade</b>	
				0	Without fade time (0=default)	step
				1-255	Fade time from min. to max.	proportional
<b>37</b>	<b>17</b>	<b>21</b>	<b>21</b>		<b>Flower Effect</b>	
				0	Open position-without Flower Effect (0=default)	step
				1 - 127	Flower Effect forwards rotation from fast to slow	proportional
				128	Flower Effect -without rotation	step
				129-255	Backwards rotation from slow to fast	proportional
<b>38</b>	<b>18</b>	<b>22</b>	<b>22</b>		<b>Flower Effect - Red (8 bit)</b>	
				0 - 255	Colour saturation control - coarse 0-100% (255=default)	proportional
<b>39</b>	<b>19</b>	<b>23</b>	<b>23</b>		<b>Flower Effect - Green (8 bit)</b>	
				0 - 255	Colour saturation control - coarse 0-100% (255=default)	proportional
<b>40</b>	<b>20</b>	<b>24</b>	<b>24</b>		<b>Flower effect - Blue (8 bit)</b>	
				0 - 255	Colour saturation control - coarse 0-100% (255=default)	proportional
<b>41</b>	<b>21</b>	<b>25</b>	<b>25</b>		<b>Flower Effect - White (8 bit)</b>	
				0-255	Colour saturation control - coarse 0-100% (255=default)	proportional
<b>42</b>	<b>22</b>	<b>26</b>	<b>26</b>		<b>Flower Effect - colour macros</b>	
					<i>(Flower Effect channel has to be set &gt; 0 DMX)</i>	step
				0	Open position - without macros (0=default) <i>(Flower effect colour macros have priority to RGBW colours/Virtual colour wheel, Flower effect colours )</i>	
				1-2	Flower Effect colour macro 1	step
				3-4	Flower Effect colour macro 2	step
				5-6	Flower Effect colour macro 3	step

DMX protocol

				119-120 121-255	: Flower Effect colour macro 60 Raw DMX	step proportional
<b>43</b>	<b>23</b>	<b>27</b>	<b>27</b>	0 - 31 32 - 63 64 - 95 96 - 127 128 - 143 144 - 159 160 - 191 192 - 223 224 - 255	<b>Flower Effect - Shutter/ strobe</b> Shutter closed Shutter open (32=default) Strobe-effect from slow to fast Shutter open Opening pulse in sequences from slow to fast Closing pulse in sequences from fast to slow Shutter open Random strobe-effect from slow to fast Shutter open	step step proportional step proportional proportional step proportional step
<b>44</b>	<b>24</b>	<b>28</b>	<b>28</b>	0 - 255	<b>Flower Effect - Dimmer intensity (8 bit)</b> Dimmer intensity from 0% to 100% (0=default)	proportional
<b>45</b>	<b>25</b>	<b>29</b>	<b>29</b>	0-255	<b>Zoom</b> Zoom from max. to min.beam angle (128=default)	proportional
<b>46</b>	*	<b>30</b>	<b>30</b>	0-255	<b>Zoom - fine</b> Fine zooming (0=default)	proportional
<b>47</b>	<b>26</b>	<b>31</b>	<b>31</b>	0 - 31 32 - 63 64 - 95 96 - 127 128 - 143 144 - 159 160 - 191 192 - 223 224 - 255	<b>Shutter/ strobe</b> Shutter closed Shutter open (32=default) Strobe-effect from slow to fast Shutter open Opening pulse in sequences from slow to fast Closing pulse in sequences from fast to slow Shutter open Random strobe-effect from slow to fast Shutter open	step step proportional step proportional proportional step proportional step
<b>48</b>	<b>27</b>	<b>32</b>	<b>32</b>	0 - 255	<b>Dimmer intensity (8 bit)</b> Dimmer intensity from 0% to 100% (0=default)	proportional
<b>49</b>	*	<b>33</b>	<b>33</b>	0 - 255	<b>Dimmer intensity - fine (16 bit)</b> Fine dimming (0=default)	proportional
*	*	*	<b>34</b>	0-255	<b>Red pixel 1</b> Red LED saturation control 0-100% (0=default)	proportional
*	*	*	<b>35</b>	0-255	<b>Green pixel 1</b> Green LED saturation control 0-100% (0=default)	proportional
*	*	*	<b>36</b>	0-255	<b>Blue pixel 1</b> Blue LED saturation control 0-100% (0=default)	proportional
					:	
*	*	*	<b>88</b>	0-255	<b>Red pixel 19</b> Red LED saturation control 0-100% (0=default)	proportional
*	*	*	<b>89</b>	0-255	<b>Green pixel 19</b> Green LED saturation control 0-100% (0=default)	proportional
*	*	*	<b>90</b>	0-255	<b>Blue pixel 19</b> Blue LED saturation control 0-100% (0=default)	proportional
* function is active only 10 seconds after switching the fixture on						
** In the Tungsten effect simulation the Dimmer channel imitates behaviour of the halogen lamp during dimming						
*** Select RGB or CMY mixing mode on channel "Power/Special functions"						

DMX protocol

Copyright © 2016-2020 Robe Lighting s.r.o. - All rights reserved					
All Specifications subject to change without notice					



DMX protocol

Robin SPIIDER - DMX protocol								
Version: 2.3 (10 modes) Mode 5-Wash, Mode 6-Pattern, Mode 7-Pixel RGB, Mode 8-Pixel RGBW, Mode 9-Pattern full RGB, Mode 10-Pattern full RGBW								
Mode/channel						DMX Value	Function	Type of control
5	6	7	8	9	10			
1	1	1	1	1	1	0 - 255	<b>Pan (8 bit)</b> Pan movement by 540° (128=default)	proportional
2	2	2	2	2	2	0 - 255	<b>Pan Fine (16 bit)</b> Fine control of pan movement (0=default)	proportional
3	3	3	3	3	3	0 - 255	<b>Tilt (8 bit)</b> Tilt movement by 220° (128=default)	proportional
4	4	4	4	4	4	0 - 255	<b>Tilt fine (16 bit)</b> Fine control of tilt movement (0=default)	proportional
5	5	5	5	5	5	0	<b>Pan/Tilt speed , Pan/Tilt time</b> Standard mode (0=default)	step
						1	Max. Speed Mode	step
						2 - 255	<b>Pan/Tilt speed mode</b> Speed from max. to min.	proportional
						2 - 255	<b>Pan/Tilt time mode</b> Time from 0.2sec. to 25.5 sec.	proportional
6	6	6	6	6	6	0-9	<b>Power/Special functions</b> Reserved (0=default) <i>To activate following functions, stop in DMX value for at least 3 s and shutter must be closed at least 3 sec. („Master Shutter/Strobe“ channel 26/45/32/32/45/45 must be at range: 0-31 DMX). Corresponding menu items are temporarily overridden ( unless otherwise stated)</i>	
						10-14	DMX input: Wired DMX	step
						15-19	DMX input: Wireless DMX *	step
							* function is active only 10 seconds after switching the fixture on	
						20-24	Graphic display ON	step
						25-29	Graphic display OFF	step
						30-34	RGBW colour mixing mode	step
						35-39	CMY colour mixing mode	step
						40-44	Pan/Tilt speed mode	step
						45-49	Pan/Tilt time mode	step
						50-54	Blackout while pan/tilt moving	step
						55-59	Disabled blackout while pan/tilt moving	step
						60-64	Dimmer curve-square law	step
						65-69	Dimmer curve-linear	step
						70-74	Fans mode: Auto	step
						75-79	Fans mode: High	step
						80-84	White point 8000K ON	step
						85-89	White point 8000K OFF	step
						90-109	Reserved	
						110-114	Kling-Net On	step
						115-119	Kling-Net Off	step
						120-124	Parking position On	step
						125-129	Parking position Off	step

DMX protocol

Mode/channel						DMX Value	Function	Type of control
5	6	7	8	9	10			
							<i>To activate following functions, stop in DMX value for at least 3 seconds (except function Pixel index and Pixel mirror). Corresponding menu items are temporarily overridden.</i>	
						130 - 139	Fixture reset (except pan/tilt)	
						140 - 149	Pan/Tilt reset	step
						150 - 159	Zoom reset	step
						160 - 169	Flower effect reset	step
						170-171	Tungsten effect simulation (750W) On **	step
						172-173	Tungsten effect simulation (1000W) On **	step
						174-175	Tungsten effect simulation (1200W) On **	step
						176-177	Tungsten effect simulation (2000W) On **	step
						178-179	Tungsten effect simulation (2500W) On **	step
						180-181	Tungsten effect simulation Off	step
						182-184	Reserved	
						185	PWM output frequency of LEDs: Standard (300Hz)*	step
						186	PWM output frequency of LEDs: High (600Hz)*	step
							* You can adjust selected frequency in 6 steps Up or Down around selected frequency - see table below . Default value of PWM frequency set in the fixture is Standard.	
						187	LED Frequency (step -6)	step
						188	LED Frequency (step -5)	step
						189	LED Frequency (step -4)	step
						190	LED Frequency (step -3)	step
						191	LED Frequency (step -2)	step
						192	LED Frequency (step -1)	step
						193	LED Frequency (Standard or High)	step
						194	LED Frequency (step +1)	step
						195	LED Frequency (step +2)	step
						196	LED Frequency (step +3)	step
						197	LED Frequency (step +4)	step
						198	LED Frequency (step +5)	step
						199	LED Frequency (step +6)	step
						200 - 209	Total fixture reset	step
						210 - 221	Pixel index	proportional
						222 - 223	Pixel mirror On	step
						224 - 225	Pixel mirror Off	step
						226 - 236	Reserved	
						237	Save Pixel index and mirror to fixture	step
							The following RoboSpot related commands are only applicable when the RoboSpot is connected:	
						238 - 239	RoboSpot enabled	step
						240 - 241	RoboSpot disabled - except handle faders and pan/tilt	step
						242 - 243	RoboSpot fully disabled	step
						244	Disabled "Silent mode"	step
						245 - 255	Silent mode - fan noise control from min. to max.	proportional
<b>7</b>	<b>7</b>	<b>7</b>	<b>7</b>	<b>7</b>	<b>7</b>		<b>Background - Virtual colour wheel</b>	
						0	No function (0=default)	step
						1-2	Filter 4 (Medium Bastard Amber)	step
						3-4	Filter 25 (Sunset Red)	step

DMX protocol

Mode/channel						DMX Value	Function	Type of control
5	6	7	8	9	10			
						5-6	Filter 19 (Fire)	step
						7-8	Filter 26 (Bright Red)	step
						9-10	Filter 58 (Lavender)	step
						11-12	Filter 68 (Sky Blue)	step
						13-14	Filter 36 (Medium Pink)	step
						15-16	Filter 89 (Moss Green)	step
						17-18	Filter 88 (Lime Green)	step
						19-20	Filter 90 (Dark Yellow Green)	step
						21-22	Filter 49 (Medium Purple)	step
						23-24	Filter 52 (Light Lavender)	step
						25-26	Filter 102 (Light Amber)	step
						27-28	Filter 103 (Straw)	step
						29-30	Filter 140 (Summer Blue)	step
						31-32	Filter 124 (Dark Green)	step
						33-34	Filter 106 (Primary Red)	step
						35-36	Filter 111 (Dark Pink)	step
						37-38	Filter 115 (Peacock Blue)	step
						39-40	Filter 126 (Mauve)	step
						41-42	Filter 117 (Steel Blue)	step
						43-44	Filter 118 (Light Blue)	step
						45-46	Filter 122 (Fern Green)	step
						47-48	Filter 182 (Light Red)	step
						49-50	Filter 121 (Filter Green)	step
						51-52	Filter 128 (Bright Pink)	step
						53-54	Filter 131 (Marine Blue)	step
						55-56	Filter 132 (Medium Blue)	step
						57-58	Filter 134 (Golden Amber)	step
						59-60	Filter 135 (Deep Golden Amber)	step
						61-62	Filter 136 (Pale Lavender)	step
						63-64	Filter 137 (Special Lavender)	step
						65-66	Filter 138 (Pale Green)	step
						67-68	Filter 798 (Chrysalis Pink)	step
						69-70	Filter 141 (Bright Blue)	step
						71-72	Filter 147 (Apricot)	step
						73-74	Filter 148 (Bright Rose)	step
						75-76	Filter 152 (Pale Gold)	step
						77-78	Filter 154 (Pale Rose)	step
						79-80	Filter 157 (Pink)	step
						81-82	Filter 143 (Pale Navy Blue)	step
						83-84	Filter 162 (Bastard Amber)	step
						85-86	Filter 164 (Flame Red)	step
						87-88	Filter 165 (Daylight Blue)	step
						89-90	Filter 169 (Lilac Tint)	step
						91-92	Filter 170 (Deep Lavender)	step
						93-94	Filter 172 (Lagoon Blue)	step
						95-96	Filter 194 (Surprise Pink)	step
						97-98	Filter 180 (Dark Lavender)	step
						99-100	Filter 181 (Congo Blue)	step

DMX protocol

Mode/channel						DMX Value	Function	Type of control
5	6	7	8	9	10			
						101-102	Filter 197 (Alice Blue)	step
						103-104	Filter 201 (Full C.T. Blue)	step
						105-106	Filter 202 (Half C.T. Blue)	step
						107-108	Filter 203 (Quarter C.T. Blue)	step
						109-110	Filter 204 (Full C.T. Orange)	step
						111-112	Filter 219 (Fluorescent Green)	step
						113-114	Filter 206 (Quarter C.T. Orange)	step
						115-116	Filter 247 (Filter Minus Green)	step
						117-118	Filter 248 (Half Minus Green)	step
						119-120	Filter 281 (Three Quarter C.T. Blue)	step
						121-122	Filter 285 (Three Quarter C.T. Orange)	step
						123-124	Filter 352 (Glacier Blue)	step
						125-126	Filter 353 (Lighter Blue)	step
						127-128	Filter 507 (Madge)	step
						129-130	Filter 778 (Millennium Gold)	step
						131-132	Filter 793 (Vanity Fair)	step
						133-235	Raw DMX	proportional
						236-245	Rainbow effect (with fade time) from slow-> fast	proportional
						246-255	Rainbow effect (without fade time) from slow-> fast	proportional
<b>8</b>	<b>8</b>	<b>8</b>	<b>8</b>	<b>8</b>	<b>8</b>		<b>Background - Red/Cyan (8 bit)***</b>	
						0 - 255	Colour saturation control - coarse 0-100% (255=default)	proportional
*	<b>9</b>	<b>9</b>	<b>9</b>	<b>9</b>	<b>9</b>		<b>Background - Red/Cyan (16bit)***</b>	
						0 - 255	Colour saturation control - fine (255=default)	proportional
<b>9</b>	<b>10</b>	<b>10</b>	<b>10</b>	<b>10</b>	<b>10</b>		<b>Background - Green/Magenta (8 bit)***</b>	
						0 - 255	Colour saturation control - coarse 0-100% (255=default)	proportional
*	<b>11</b>	<b>11</b>	<b>11</b>	<b>11</b>	<b>11</b>		<b>Background - Green/Magenta (16bit) ***</b>	
						0 - 255	Colour saturation control - fine (255=default)	proportional
<b>10</b>	<b>12</b>	<b>12</b>	<b>12</b>	<b>12</b>	<b>12</b>		<b>Background - Blue/Yellow (8 bit)***</b>	
						0 - 255	Colour saturation control - coarse 0-100% (255=default)	proportional
*	<b>13</b>	<b>13</b>	<b>13</b>	<b>13</b>	<b>13</b>		<b>Background - Blue/ Yellow (16bit)***</b>	
						0 - 255	Colour saturation control - fine (255=default)	proportional
<b>11</b>	<b>14</b>	<b>14</b>	<b>14</b>	<b>14</b>	<b>14</b>		<b>Background - White (8 bit) - all pixels</b>	
							<i>If RGBW mode is selected:</i>	
						0-255	Colour saturation control - coarse 0-100% (255=default)	proportional
							<i>If CMY mode is selected:</i>	
						0 - 255	No function	
*	<b>15</b>	<b>15</b>	<b>15</b>	<b>15</b>	<b>15</b>		<b>Background - White (16 bit) - all pixels</b>	
						0 - 255	Colour saturation control - fine (255=default)	proportional
<b>12</b>	<b>16</b>	<b>16</b>	<b>16</b>	<b>16</b>	<b>16</b>		<b>Background - CTC</b>	
							<i>If function "White Point 8000K" is ON</i>	
						0-255	Col. temperature correction from 8000K to 2700K -for whites only (0=8000K, 64=5600K, 128=4200K, 192=3200K, 255=2700K) To get colour temperatures stated above, RGBW channels have to be set at the same value (e.g. 255DMX) or RGB=0 and White channel > 0 DMX (0=default) (To activate Tungsten effect at 2700K and 3200K , set DMX value at "Power/Special functions" channel)	proportional
							<i>If function "White Point 8000K" is OFF</i>	
						0-255	Colour temperature correction from cool col. to warm colour	proportional

DMX protocol

Mode/channel						DMX Value	Function	Type of control
5	6	7	8	9	10			
13	17	17	17	17	17		<b>Background - Shutter/ strobe</b>	
						0 - 31	Shutter closed	step
						32 - 63	Shutter open (32=default)	step
						64 - 95	Strobe effect from slow to fast	proportional
						96 - 127	Shutter open	step
						128 - 143	Opening pulse in sequences from slow to fast	proportional
						144 - 159	Closing pulse in sequences from fast to slow	proportional
						160 - 191	Shutter open	step
						192 - 223	Random strobe effect from slow to fast	proportional
						224 - 255	Shutter open	step
14	18	18	18	18	18		<b>Background - Dimmer intensity (8 bit)</b>	
						0 - 255	Dimmer intensity from 0% to 100% (255=default)	proportional
*	19	19	19	19	19		<b>Background Dimmer intensity - fine (16 bit)</b>	
						0 - 255	Fine dimming (255=default)	proportional
15	20	20	20	20	20		<b>Background - Active zone</b>	
						0-2	All pixels (0=default)	
						3-4	Ring 1 (Middle pixel)	step
						5-6	Ring 2	step
						7-8	Ring 3	step
						9-10	Ring 1+ Ring 2	step
						11-12	Ring 1+ Ring 3	step
						13-14	Ring 2 + Ring 3	step
						15-16	Sector 1	step
						17-18	Sector 2	step
						19-20	Sector 3	step
						21-22	Sector 4	step
						23-24	Sector 5	step
						25-26	Sector 6	step
						27-28	Sector 1+4	step
						29-30	Sector 1+4+Ring 1	step
						31-32	Sector 2+5	step
						33-34	Sector 2+5+Ring 1	step
						35-36	Sector 3+6	step
						37-38	Sector 3+6+Ring 1	step
						39-40	Sector 1+3+5	step
						41-42	Sector 1+3+5+Ring 1	step
						43-44	Sector 2+4+6	step
						45-46	Sector 2+4+6+Ring 1	step
						47-48	Sector 1+2+3	step
						49-50	Sector 2+3+4	step
						51-52	Sector 3+4+5	step
						53-54	Sector 4+5+6	step
						55-56	Sector 5+6+1	step
						57-58	sector 6+1+2	step
						59-255	Raw DMX	proportional
16	21	21	21	21	21		<b>Colour Mix control</b>	
							<i>The channel defines relation between color channels</i>	
							<b><i>IF Flower effect is active, its colour channels always have priority!</i></b>	

DMX protocol

Mode/channel						DMX Value	Function	Type of control
5	6	7	8	9	10			
							<i>Global = Global Colours (Background RGBW, Background Virtual Colour Wheel, Background CTC)</i>	
							<i>Pixel = Pixel Colours (RGB individual pixels or Kling-Net)</i>	
						0-9	Global colours (Global has priority)	
						10-19	Maximum mode (highest values have priority)	step
						20-29	Minimum mode (lowest values have priority)	step
						30-39	Multiply mode (multiply Global and Pixel)	step
						40-49	Addition mode (Global + Pixel) (45=default)	step
						50-59	Subtraction mode (Global – Pixel)	step
						60-69	Inverted Subtraction mode (Pixel – Global)	step
						70-79	Coloured background	step
						80-127	Raw DMX	proportional
						128	Global colours only (Global has priority)	step
						129-254	Crossfade (crossfade between Global and Pixel)	proportional
						255	Pixel colours (Pixel has priority)	step
17	22	22	22	22	22		<b>Flower Effect</b>	
						0	Open position-without Flower Effect (0=default)	step
						1 - 127	Flower Effect forwards rotation from fast to slow	proportional
						128	Flower Effect -without rotation	step
						129-255	Backwards rotation from slow to fast	proportional
18	23	23	23	23	23		<b>Flower Effect - Red/Cyan (8 bit)</b>	
						0 - 255	Colour saturation control - coarse 0-100% (255=default)	proportional
19	24	24	24	24	24		<b>Flower Effect - Green/Magenta (8 bit)</b>	
						0 - 255	Colour saturation control - coarse 0-100% (255=default)	proportional
20	25	25	25	25	25		<b>Flower effect - Blue/Yellow (8 bit)</b>	
						0 - 255	Colour saturation control - coarse 0-100% (255=default)	proportional
21	26	26	26	26	26		<b>Flower Effect - White (8 bit)</b>	
						0-255	Colour saturation control - coarse 0-100% (255=default)	proportional
22	27	27	27	27	27		<b>Flower Effect - colour macros</b>	
							<i>(Flower Effect channel has to be set &gt; 0 DMX)</i>	
						0	Open position - without macros (0=default)	step
							<i>(Flower effect colour macros have priority to RGBW colours/Virtual colour wheel, Flower effect colours, channels Flower effect-Shutter/strobe and Flower effect-dimmer has to be open )</i>	
						1-2	Flower Effect colour macro 1	step
						3-4	Flower Effect colour macro 2	step
						5-6	Flower Effect colour macro 3	step
						:		
						119-120	Flower Effect colour macro 60	step
						121-255	Raw DMX	proportional
23	28	28	28	28	28		<b>Flower Effect - Shutter/ strobe</b>	
						0 - 31	Shutter closed	step
						32 - 63	Shutter open (32=default)	step
						64 - 95	Strobe-effect from slow to fast	proportional
						96 - 127	Shutter open	step
						128 - 143	Opening pulse in sequences from slow to fast	proportional
						144 - 159	Closing pulse in sequences from fast to slow	proportional
						160 - 191	Shutter open	step
						192 - 223	Random strobe-effect from slow to fast	proportional

DMX protocol

Mode/channel						DMX Value	Function	Type of control
5	6	7	8	9	10			
						224 - 255	Shutter open	step
24	29	29	29	29	29	0 - 255	<b>Flower Effect - Dimmer intensity (8 bit)</b> Dimmer intensity from 0% to 100% (255=default)	proportional
25	30	30	30	30	30	0-255	<b>Zoom</b> Zoom from max. to min.beam angle (128=default)	proportional
*	31	31	31	31	31	0-255	<b>Zoom - fine</b> Fine zooming (0=default)	proportional
*	32	*	*	32	32	0-2	<b>Pattern selection</b> No pattern (0=default)	
						3-4	Pattern 1	step
						5-6	Pattern 2	step
						7-8	Pattern 3	step
						9-10	Pattern 4	step
						11-12	Pattern 5	step
						13-14	Pattern 6	step
						15-16	Pattern 7	step
						17-18	Pattern 8	step
						19-20	Pattern 9	step
						21-22	Pattern 10	step
						23-24	Pattern 11	step
						25-26	Pattern 12	step
						27-28	Pattern 13	step
						29-30	Pattern 14	step
						31-255	RAW DMX	proportional
*	33	*	*	33	33	0-2	<b>Pattern - Repeat (Size)</b> Variant 1 (0=default)	step
						3-4	Variant 2	step
						5-6	Variant 3	step
						7-8	Variant 4	step
						9-10	Variant 5	step
						11-12	Variant 6	step
						13-14	Variant 7	step
						15-16	Variant 8	step
						17-18	Variant 9	step
						19-20	Variant 10	step
						21-22	Variant 11	step
						23-255	Raw DMX	proportional
*	34	*	*	34	34	0	<b>Pattern - Rotation</b> No rotation (0=default)	step
						1-127	Pattern indexing	proportional
						128-190	Forwards rotation from fast to slow	proportional
						191-192	Pause - without rotation	step
						193-255	Backwards rotation from slow to fast	proportional
*	35	*	*	35	35	0	<b>Pattern - Fade</b> Snap (0=default)	step
						1-255	Fade from min. to max.	proportional
*	36	*	*	36	36	0	<b>Pattern -Transition</b> No fade (0=default)	step

DMX protocol

Mode/channel						DMX Value	Function	Type of control
5	6	7	8	9	10			
						1	100ms	step
						255	4 sec	step
*	37	*	*	37	37	0	<b>Pattern - Crossfade</b> Background	step
						1-255	Crossfade between Background and Pattern 0-100% (255=default)	proportional
*	38	*	*	38	38	0 - 255	<b>Pattern - Red (8-bit)</b> Colour saturation control - coarse 0-100% (255=default)	proportional
*	39	*	*	39	39	0 - 255	<b>Pattern - Green (8-bit)</b> Colour saturation control - coarse 0-100% (255=default)	proportional
*	40	*	*	40	40	0 - 255	<b>Pattern - Blue (8-bit)</b> Colour saturation control - coarse 0-100% (255=default)	proportional
*	41	*	*	41	41	0 - 255	<b>Pattern - White (8-bit)</b> Colour saturation control - coarse 0-100% (255=default)	proportional
*	42	*	*	42	42	0-2	<b>Pattern - Colour macro</b> No macro (0=default)	step
							<i>Macros 1-15 allow control of colour change speed from max. to min.</i>	
						3-8	Macro 1	proportional
						9-14	Macro 2	proportional
						15-20	Macro 3	proportional
						21-26	Macro 4	proportional
						27-32	Macro 5	proportional
						33-38	Macro 6	proportional
						39-44	Macro 7	proportional
						45-50	Macro 8	proportional
						51-56	Macro 9	proportional
						57-62	Macro 10	proportional
						63-68	Macro 11	proportional
						69-74	Macro 12	proportional
						75-80	Macro 13	proportional
						81-86	Macro 14	proportional
						87-92	Macro 15	proportional
						93-98	Macro 16	step
						99-104	Macro 17	step
						105-110	Macro 18	step
						111-255	Raw DMX	proportional
*	43	*	*	43	43	0 - 31	<b>Pattern - Shutter/ strobe</b> Shutter closed	step
						32 - 63	Shutter open (32=default)	step
						64 - 95	Strobe effect from slow to fast	proportional
						96 - 127	Shutter open	step
						128 - 143	Opening pulse in sequences from slow to fast	proportional
						144 - 159	Closing pulse in sequences from fast to slow	proportional
						160 - 191	Shutter open	step
						192 - 223	Random strobe effect from slow to fast	proportional
						224 - 255	Shutter open	step
*	44	*	*	44	44	0 - 255	<b>Pattern - Dimmer intensity (8 bit)</b> Dimmer intensity from 0% to 100% (255=default)	proportional



DMX protocol

Mode/channel						DMX Value	Function	Type of control
5	6	7	8	9	10			
26	45	32	32	45	45		<b>Master Shutter/ strobe</b>	
						0 - 31	Shutter closed	step
						32 - 63	Shutter open (32=default)	step
						64 - 95	Strobe effect from slow to fast	proportional
						96 - 127	Shutter open	step
						128 - 143	Opening pulse in sequences from slow to fast	proportional
						144 - 159	Closing pulse in sequences from fast to slow	proportional
						160 - 191	Shutter open	step
						192 - 223	Random strobe effect from slow to fast	proportional
						224 - 255	Shutter open	step
27	46	33	33	46	46		<b>Master Dimmer intensity (8 bit)</b>	
						0 - 255	Dimmer intensity from 0% to 100% (0=default)	proportional
*	47	34	34	47	47		<b>Master Dimmer intensity - fine (16 bit)</b>	
						0 - 255	Fine dimming (0=default)	proportional
*	*	35	35	48	48		<b>Red pixel 1</b>	
						0-255	Red LED saturation control 0-100% (0=default)	proportional
*	*	36	36	49	49		<b>Green pixel 1</b>	
						0-255	Green LED saturation control 0-100% (0=default)	proportional
*	*	37	37	50	50		<b>Blue pixel 1</b>	
						0-255	Blue LED saturation control 0-100% (0=default)	proportional
*	*	*	38	*	51		<b>White pixel 1</b>	
						0-255	White LED saturation control 0-100% (0=default)	proportional
							:	
*	*	89	107	102	120		<b>Red pixel 19</b>	
						0-255	Red LED saturation control 0-100% (0=default)	proportional
*	*	90	108	103	121		<b>Green pixel 19</b>	
						0-255	Green LED saturation control 0-100% (0=default)	proportional
*	*	91	109	104	122		<b>Blue pixel 19</b>	
						0-255	Blue LED saturation control 0-100% (0=default)	proportional
*	*	*	110	*	123		<b>White pixel 19</b>	
						0-255	White LED saturation control 0-100% (0=default)	proportional
* function is active only 10 seconds after switching the fixture on								
** In the Tungsten effect simulation the Dimmer channel imitates behaviour of the halogen lamp during dimming								
*** Select RGB or CMY mixing mode on channel "Power/Special functions"								
Copyright © 2016 -2020 Robe Lighting s.r.o. - All rights reserved								

<b>Robin Spiider - colours on Virtual Colour Wheel</b>				
<b>Colour name</b>	<b>Red (DMX)</b>	<b>Green (DMX)</b>	<b>Blue (DMX)</b>	<b>White (DMX)</b>
Filter 4 (Medium Bastard Amber)	255	118	0	109
Filter 25 (Sunset Red)	255	50	0	3
Filter 19 (Fire)	255	13	0	0
Filter 26 (Bright Red)	255	0	0	0
Filter 58 (Lavender)	117	0	97	110
Filter 68 (Sky Blue)	42	195	100	0
Filter 36 (Medium Pink)	255	74	8	24
Filter 89 (Moss Green)	69	245	0	3
Filter 88 (Lime Green)	187	226	0	0
Filter 90 (Dark Yellow Green)	0	255	1	0
Filter 49 (Medium Purple)	255	0	27	0
Filter 52 (Light Lavender)	227	86	14	134
Filter 102 (Light Amber)	233	164	0	0
Filter 103 (Straw)	207	137	0	33
Filter 140 (Summer Blue)	0	161	7	218
Filter 124 (Dark Green)	29	255	0	12
Filter 106 (Primary Red)	242	1	1	0
Filter 111 (Dark Pink)	255	67	11	49
Filter 115 (Peacock Blue)	0	255	28	41
Filter 126 (Mauve)	255	0	39	0
Filter 117 (Steel Blue)	163	255	14	161
Filter 118 (Light Blue)	0	255	61	34
Filter 122 (Fern Green)	98	255	3	2
Filter 182 (Light Red)	255	16	2	0
Filter 121 (Filter Green)	165	255	0	0
Filter 128 (Bright Pink)	255	0	13	32
Filter 131 (Marine Blue)	73	245	27	30
Filter 132 (Medium Blue)	0	193	113	0
Filter 134 (Golden Amber)	191	83	0	0
Filter 135 (Deep Golden Amber)	255	52	0	0
Filter 136 (Pale Lavender)	164	96	29	54
Filter 137 (Special Lavender)	130	60	63	102
Filter 138 (Pale Green)	226	255	0	51
Filter 798 (Chrysalis Pink)	49	0	98	14
Filter 141 (Bright Blue)	8	176	62	0
Filter 147 (Apricot)	215	104	0	15
Filter 148 (Bright Rose)	255	3	0	37
Filter 152 (Pale Gold)	202	115	0	39
Filter 154 (Pale Rose)	214	107	0	48
Filter 157 (Pink)	255	56	5	48
Filter 143 (Pale Navy Blue)	0	193	72	148
Filter 162 (Bastard Amber)	223	153	6	41
Filter 164 (Flame Red)	255	27	0	4
Filter 165 (Daylight Blue)	23	236	87	81
Filter 169 (Lilac Tint)	206	123	0	110
Filter 170 (Deep Lavender)	235	123	41	33
Filter 172 (Lagoon Blue)	0	255	54	0

<b>Colour name</b>	<b>Red (DMX)</b>	<b>Green (DMX)</b>	<b>Blue (DMX)</b>	<b>White (DMX)</b>
Filter 194 (Surprise Pink)	110	0	21	255
Filter 180 (Dark Lavender)	136	43	181	89
Filter 181 (Congo Blue)	37	0	255	0
Filter 197 (Alice Blue)	107	220	129	0
Filter 201 (Full C.T. Blue)	179	255	57	34
Filter 202 (Half C.T. Blue)	217	255	37	3
Filter 203 (Quarter C.T. Blue)	236	255	30	3
Filter 204 (Full C.T. Orange)	230	125	3	7
Filter 219 (Fluorescent Green)	99	148	16	50
Filter 206 (Quarter C.T. Orange)	204	140	0	57
Filter 247 (Filter Minus Green)	255	81	0	193
Filter 248 (Half Minus Green)	255	144	0	137
Filter 281 (Three Quarter C.T. Blue)	225	255	72	160
Filter 285 (Three Quarter C.T. Orange)	199	124	0	17
Filter 352 (Glacier Blue)	0	161	65	90
Filter 353 (Lighter Blue)	0	115	37	97
Filter 507 (Madge)	255	31	0	0
Filter 778 (Millennium Gold)	255	65	0	0
Filter 793 (Vanity Fair)	255	0	13	16