



evolution wired e 906



The supercardioid e 906 instrument microphone was especially designed for guitar amplifiers, but it is also an excellent choice for percussion and brass instruments.

FEATURES

- Lively, full sound
- Very fast attack
- Flat shape is ideal for miking amp faces
- Three-position switchable presence filter for adaption of the sound characteristics: bright, moderate, dark
- Extra-resistant reinforced metal body

DELIVERY INCLUDES

- e 906
- pouch
- MZQ 100 microphone clamp
- quick guide
- safety guide

SPECIFICATIONS

| | |
|------------------------------------|------------------|
| Transducer principle | dynamic |
| Frequency response | 40 - 18,000 Hz |
| Pick-up pattern | super-cardioid |
| Sensitivity (free field, at 1 kHz) | 2.2 mV/Pa |
| Nominal impedance (at 1 kHz) | 350 Ω |
| Min. terminating impedance | 1 k Ω |
| Connector | XLR-3 |
| Dimensions | 55 x 34 x 134 mm |
| Weight | 140 g |

ARCHITECT'S SPECIFICATION

The instrument microphone shall be a dynamic super-cardioid designed for use with guitar amps, percussion and brass instruments. The microphone shall have a rugged metal body and shall provide a three-position switchable presence filter that allows the adaption of the sound characteristics.

The frequency response shall be 40 Hz – 18,000 Hz and the sensitivity (free field, no load) shall be 2.2 mV/Pa at 1 kHz. Nominal impedance shall be 350 Ω , with a min. terminating impedance of 1 k Ω .

The microphone shall provide a 3-pin XLR connector. Dimensions shall be 55 x 34 x 134 mm (2.17" x 1.34" x 5.28"). Weight shall be 140 grams (4.94 oz).

The microphone shall be the Sennheiser e 906.



evolution wired e 906

DIMENSIONS

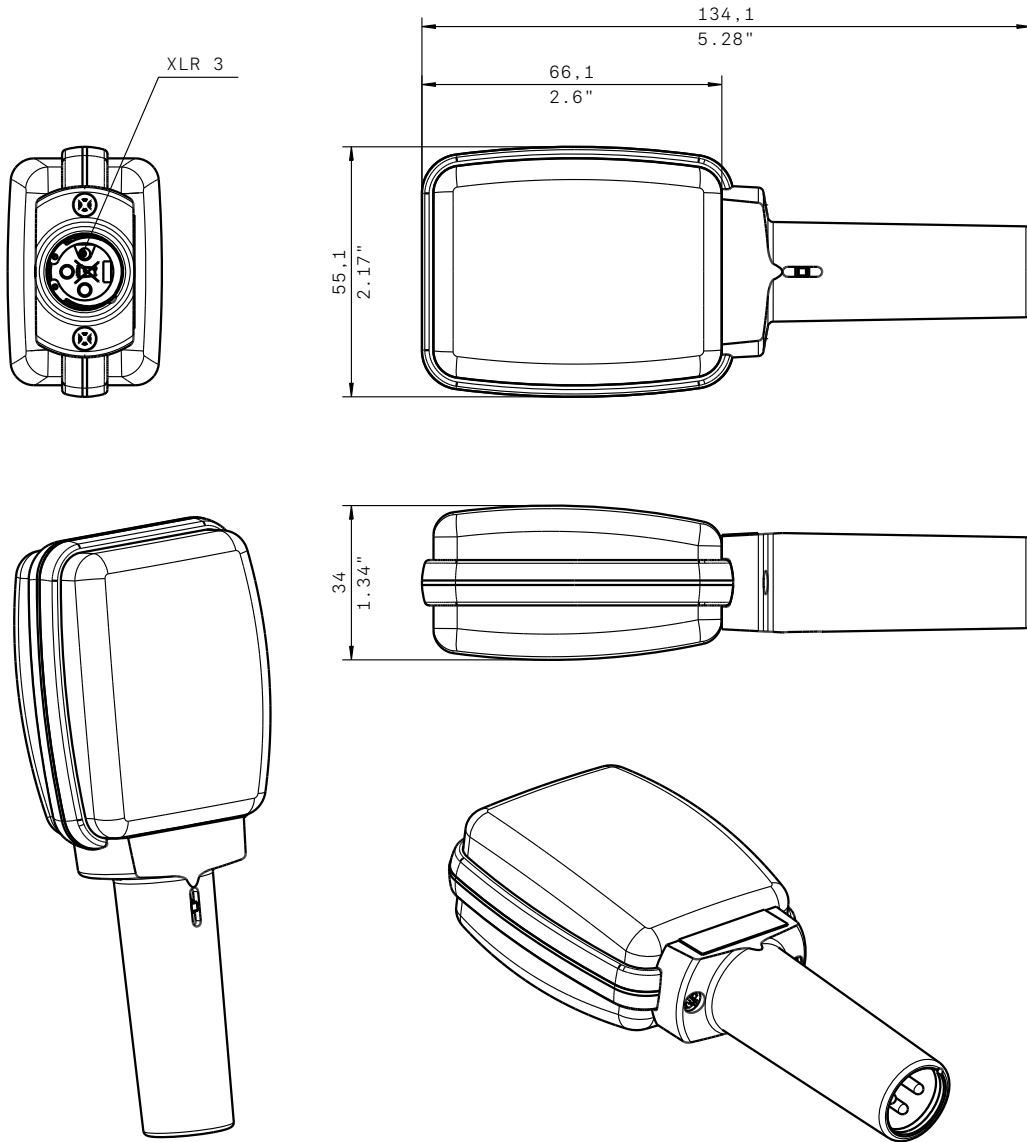

POLAR PATTERN

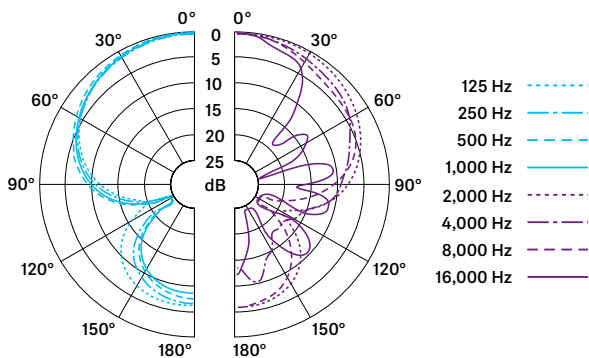

FREQUENCY RESPONSE

